

# **AKAI**

PRO **1000**

**SERVICE MANUAL**

# I. TECHNICAL DATA

RECORDING TRACK SYSTEM		2-track, 2-channel stereo system
PLAYBACK TRACK SYSTEM		2-track, 2-channel stereo system 4-track, 2-channel stereo system
MAXIMUM REEL SIZE		Size 26 (No. 10)
TAPE SPEED		38cm/sec, 19cm/sec, 9.5cm/sec
TAPE SPEED DEVIATION		±0.5%
WOW AND AND FLUTTER		38cm/sec: 0.025% WRMS 19cm/sec: 0.04% WRMS 9.5cm/sec: 0.08% WRMS
TAPE RISING CHARACTERISTICS		0.8 sec at 38cm/sec speed (Time from start-up to time wow and flutter enter specified value)
FREQUENCY CHARACTERISTICS		38cm/sec, 0VU recording: 50~20,000Hz, ±1dB 19cm/sec, 0VU recording: 40~24,000Hz, ±3dB 9.5cm/sec, 0VU recording: 60~12,000Hz, ±3dB
OVERALL HARMONICS DISTORTION RATE		Not more than 1%, 1kHz, 0VU (38cm/sec, 19cm/sec, 9.5cm/sec)
TOTAL S/N RATIO		60dB
PLAYBACK COMPENSATION CHARACTERISTICS		NAB
ERASE RATIO		70dB
RECORDING BIAS FREQUENCY		150kHz
HEADS (4)		2-track recording GX head, 2-track playback GX head 4-track playback GX head, Full-track erase head
MOTORS (3)		AC servo, oil circulating type, no-oil-supply motor with built-in CPG for capstan drive × 1 Oil-circulating type, no-oil-supply, 6-pole, eddy current motor × 2
FAST-FORWARDING AND REWINDING TYPE		Within 120 sec (for 740m tape)
INPUT	MICROPHONE (4)	Optimum impedance: 600~10 kohms Minimum input level: 0.3mV/-69dB
	LINE (4)	Input impedance: 100 kohms Minimum input level: 70mV/-21dB
OUTPUT	LINE (4)	Load impedance: Not less than 10 kohms Output impedance: Not more than 100 ohms Reference output: 0dB (0.775V)
	MIXER (2)	Load impedance: Not less than 20 kohms Output impedance: Not more than 1 kohms Output level: 300mV
	HEADPHONES	50mV/8 ohms
LEVEL METER	PEAK	Conforms to DIN Standard, Response time: 0.01 sec Meter return time: 0.8 sec
	VU	Conforms to BTS Standard
SEMI-CONDUCTORS		130 transistors, 4 diodes, 6 FETs and 2 ICs.
POWER SUPPLY		100V AC, 50/60Hz
POWER CONSUMPTION		116W
EXTERNAL DIMENSIONS (W × H × D)		Mechanism section: 486 × 412 × 284mm Amplifier section: 486 × 231 × 309mm
WEIGHT		Mechanism section: 28.3kg Amplifier section: 10.2kg
STANDARD ACCESSORIES		Metalic Size 26 (No. 10) empty reel × 1, reel hub adapter × 2, recording connection cord × 1 set, sensing tape × 1 and operator's manual × 1

\* Technical Data and external appearance are subject to change without notice.

\* If not stated otherwise, the Technical Data are those obtained through measurements carried out in conformity with methods specified in the Japanese Industrial Standard (JIS) and with SCOTCH #206 used as the standard tape.

# II. CONTROLS

## 1. MECHANISM SECTION

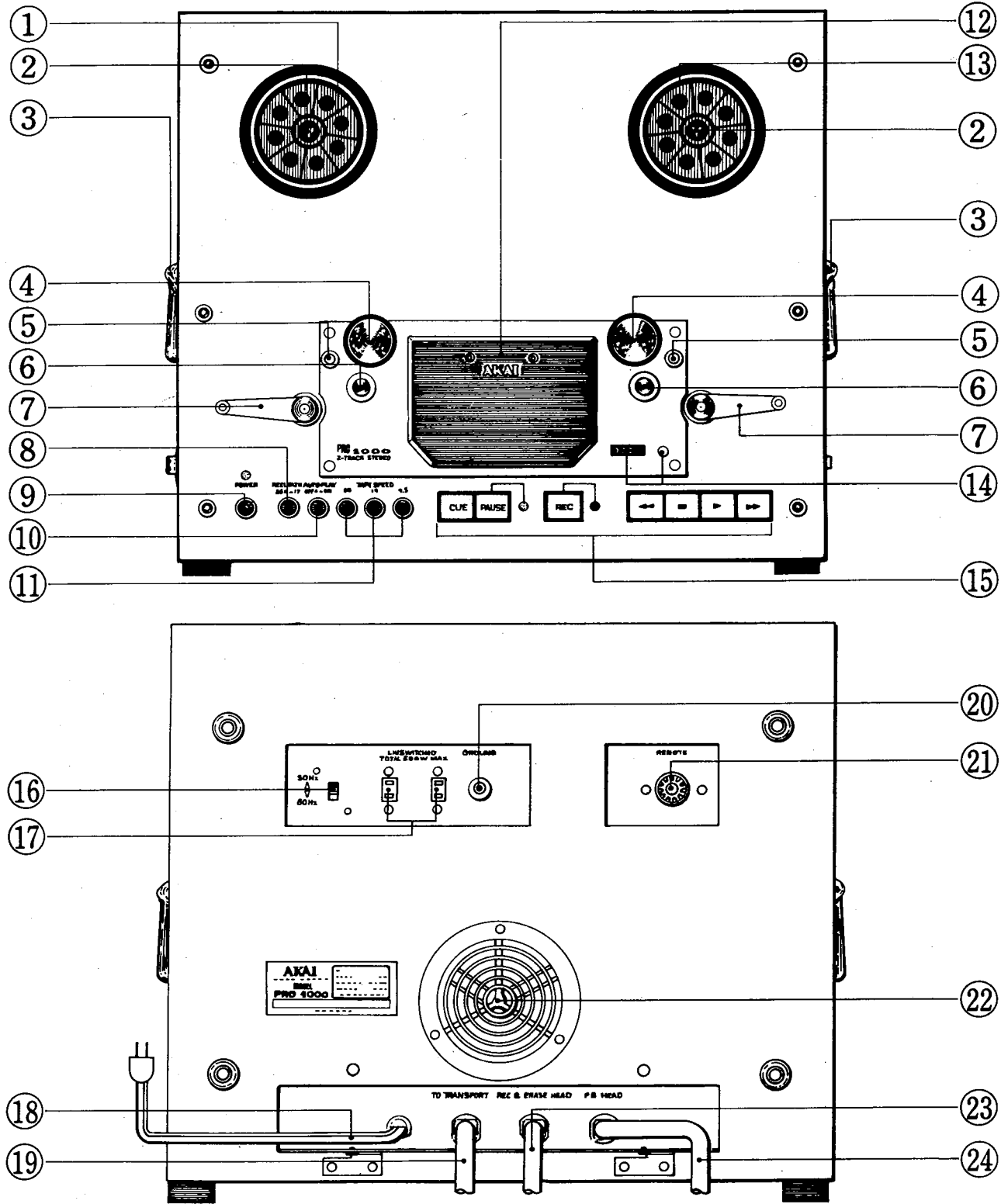

- 
- 1 SUPPLY REEL TABLE
  - 2 REEL RETAINER
  - 3 HANDLE
  - 4 PINCH ROLLER
  - 5 TAPE GUIDE
  - 6 CAPSTAN
  - 7 TENSION LEVER
  - 8 REEL SIZE SELECTOR (REEL SIZE)
  - 9 POWER SWITCH (POWER)
  - 10 AUTOMATIC PLAY SWITCH (AUTO PLAY)
  - 11 TAPE SPEED SELECTOR (TAPE SPEED)
  - 12 HEAD COVER
  - 13 TAKE-UP REEL TABLE
  - 14 INDEX COUNTER AND RESET BUTTON
  - 15 OPERATING BUTTONS
    - PLAY BUTTON ( ▶ )
    - EAST FORWARD BUTTON ( ▶▶ )
    - REWIND BUTTON ( ◀◀ )
    - STOP BUTTON ( ■ )
    - RECORDING BUTTON (REC)
    - PAUSE BUTTON (PAUSE)
    - CUE BUTTON (CUE)
  - 16 CYCLE CHANGE SWITCH
  - 17 AC OUTLET
  - 18 POWER CORD
  - 19 CONNECTING CORD FOR MECHANICAL SECTION (TO TRANSPORT)
  - 20 EARTH TERMINAL
  - 21 REMOTE CONTROL JACK
  - 22 VENTILATOR
  - 23 CONNECTING CORD FOR RECORD AND ERASE HEADS (REC/ERASE HEADS)
  - 24 CONNECTING CORD FOR PLAYBACK HEADS (P.B. HEADS)
-

## 2. AMPLIFIER SECTION

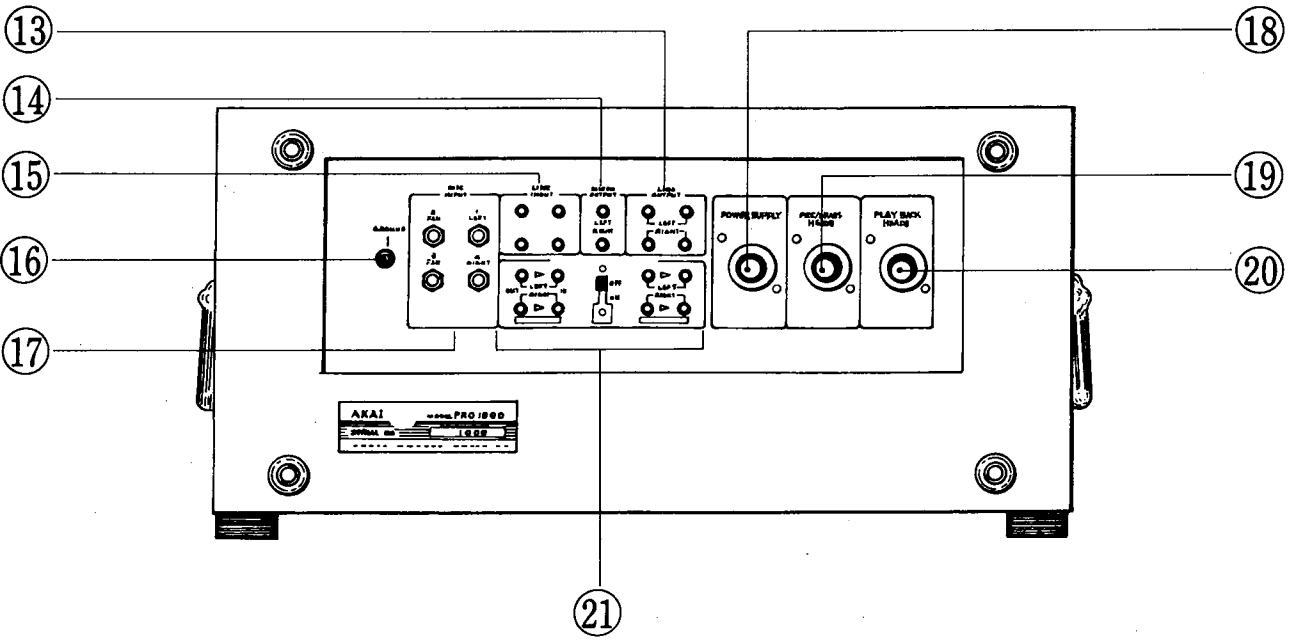
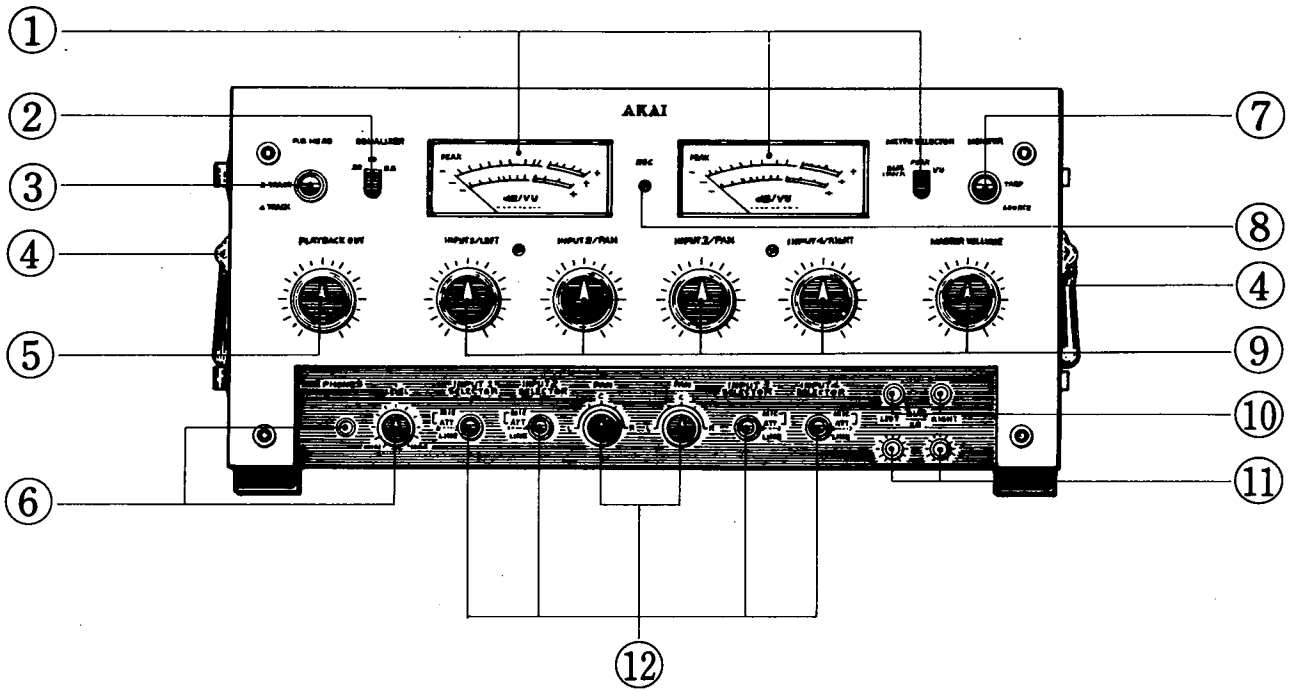

- 
- 1 LEVEL METERS AND METER SELECTOR (METER SELECTOR)
  - 2 EQUALIZER CHANGE SWITCH (EQUALIZER)
  - 3 PLAYBACK HEAD CHANGE SWITCH (P.B. HEAD)
  - 4 HANDLE
  - 5 OUTPUT LEVEL ADJUSTMENT CONTROL (PLAYBACK OUT)
  - 6 HEADPHONE JACK AND HEADPHONE OUTPUT LEVEL ADJUSTMENT CONTROL
  - 7 MONITOR SWITCH (MONITOR)
  - 8 RECORDING INDICATOR LAMP (REC)
  - 9 RECORDING INPUT LEVEL ADJUSTMENT CONTROL (WITH PRESET MECHANISM)
    - INPUT 1/LEFT
    - INPUT 2/PAN
    - INPUT 3/PAN
    - INPUT 4/RIGHT
    - MASTER VOLUME
  - 10 BIAS ADJUSTMENT CONTROL (BIAS)
  - 11 EQUALIZER ADJUSTMENT CONTROL (EQ)
  - 12 INPUT SELECTOR (INPUTS 1 ~ 4)
    - PANPOT CONTROL (PAN)
    - MICROPHONE ATTENUATOR (MIC ATT)
  - 13 LINE OUTPUT JACK (LINE OUTPUT)
  - 14 MIXER OUTPUT JACKS (MIXER OUTPUT)
  - 15 LINE INPUT JACKS (LINE INPUT)
  - 16 EARTH TERMINAL
  - 17 MICROPHONE INPUT JACK (MIC INPUT)
  - 18 SOCKET FOR MECHANICAL SECTION (TRANSPORT)
  - 19 PLUG FOR RECORDING AND ERASE HEADS (REC/ERASE HEADS)
  - 20 SOCKET FOR PLAYBACK HEADS (P.B. HEADS)
  - 21 EXTERNAL NR PROCESSOR JACKS AND SWITCH
-

---

### III. MECHANISM ADJUSTMENT

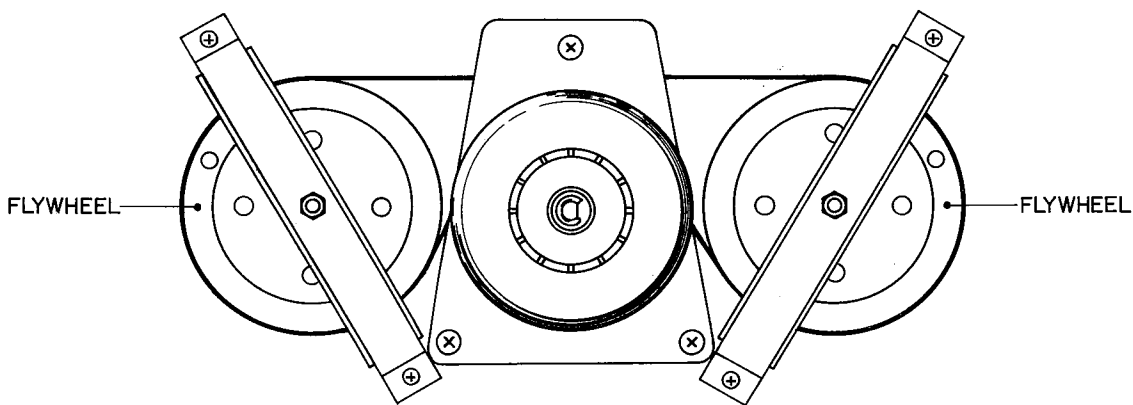

Fig. 1

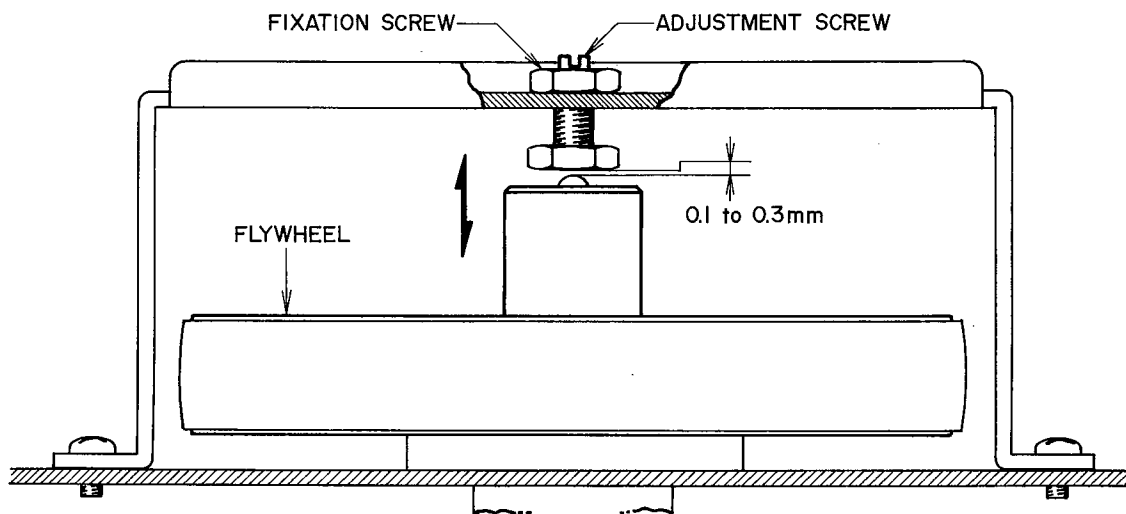

Fig. 2

#### 1. FLYWHEEL THRUST LOOSE PLAY ADJUSTMENT

As shown in Fig. 2, move the flywheel in the direction of the arrow mark and arrange the bearings so that the flywheel has 0.1 – 0.3mm of thrust loose play. Then fix the bearings in place with the nut. Caution When Replacing Flywheel

- 1) Each flywheel bears a letter of the alphabet. Make sure the new flywheel has the same letter as the old one.
- 2) Make sure you don't switch flywheels when replacing both at the same time.

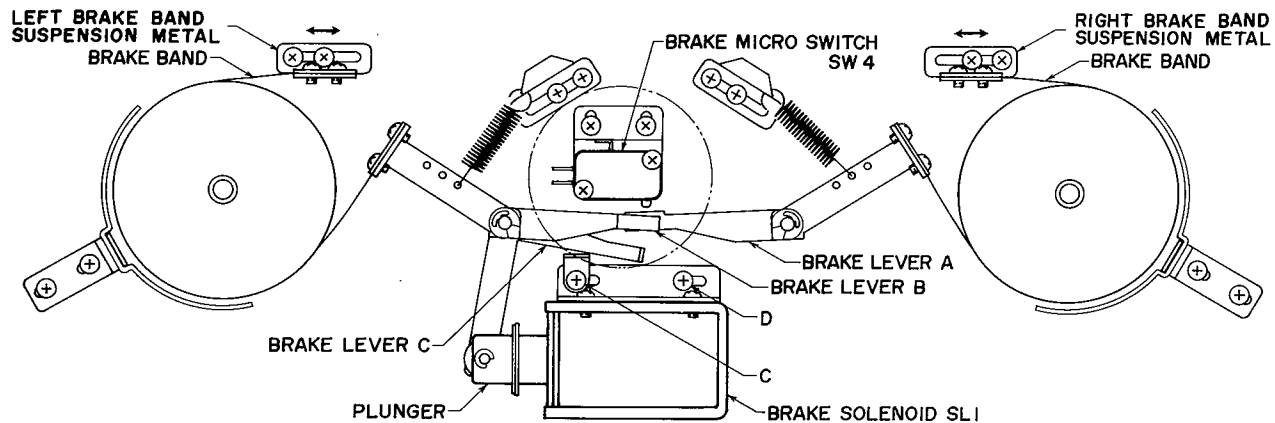

Fig. 3



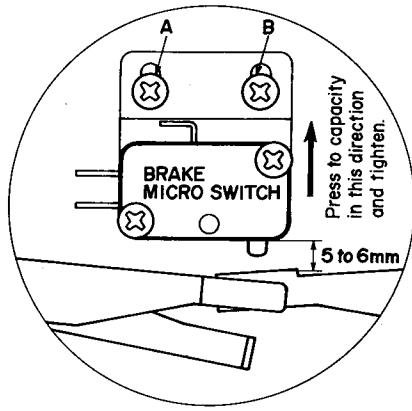

Fig. 4

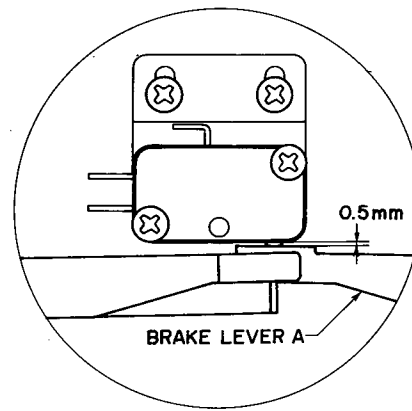

Fig. 5

## 2. BRAKE SOLENOID POSITION ADJUSTMENT

- 1) As indicated in Fig. 4, pull the brake micro switch above the mechanism frame and tighten screws A and B.
- 2) As in Fig. 3, move the right brake band suspension metal until a 5 – 6mm space between brake lever A and the body of the brake micro switch is attained. (Refer to Fig. 4.)
- 3) Move the left brake band support as indicated in Fig. 3 so that brake levers B and A can be simultaneously operated by brake lever C.
- 4) As illustrated in Fig. 5, tighten brake solenoid fixing screws C and D so that there is a minimum of 0.5mm between brake lever A and the body of the brake micro switch when the plunger is pulled.

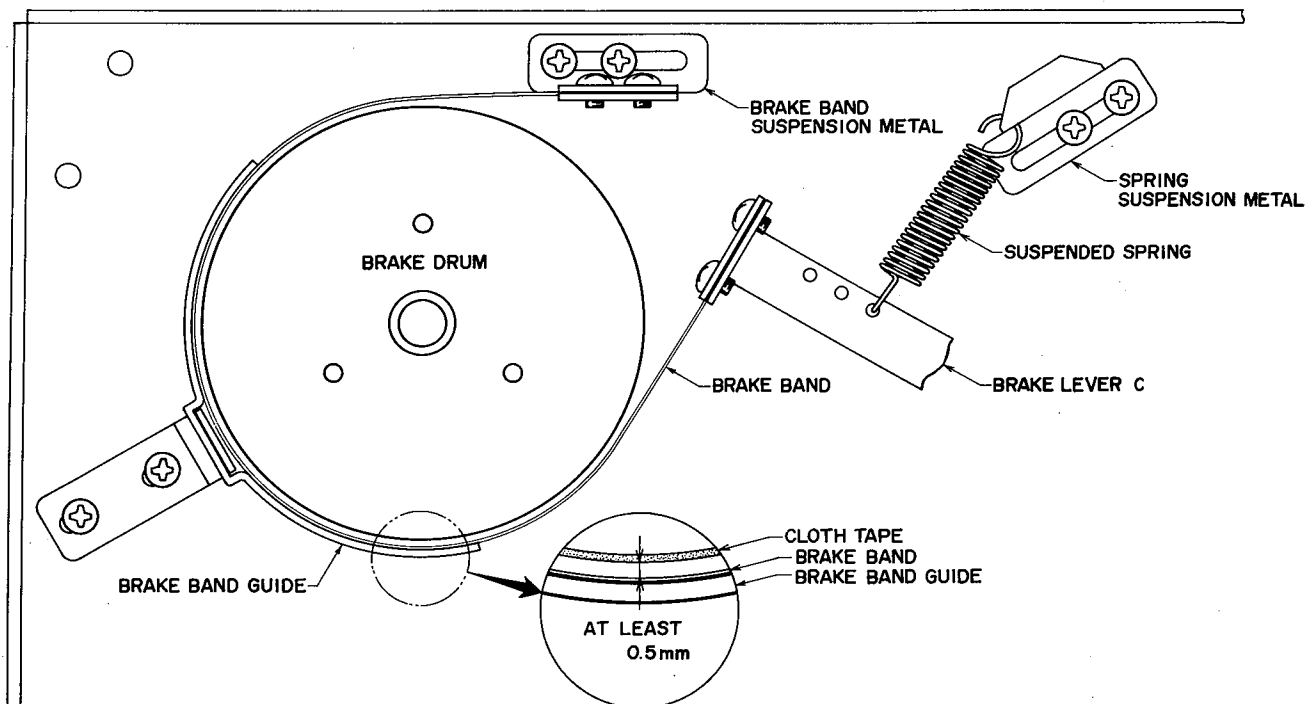

Fig. 6

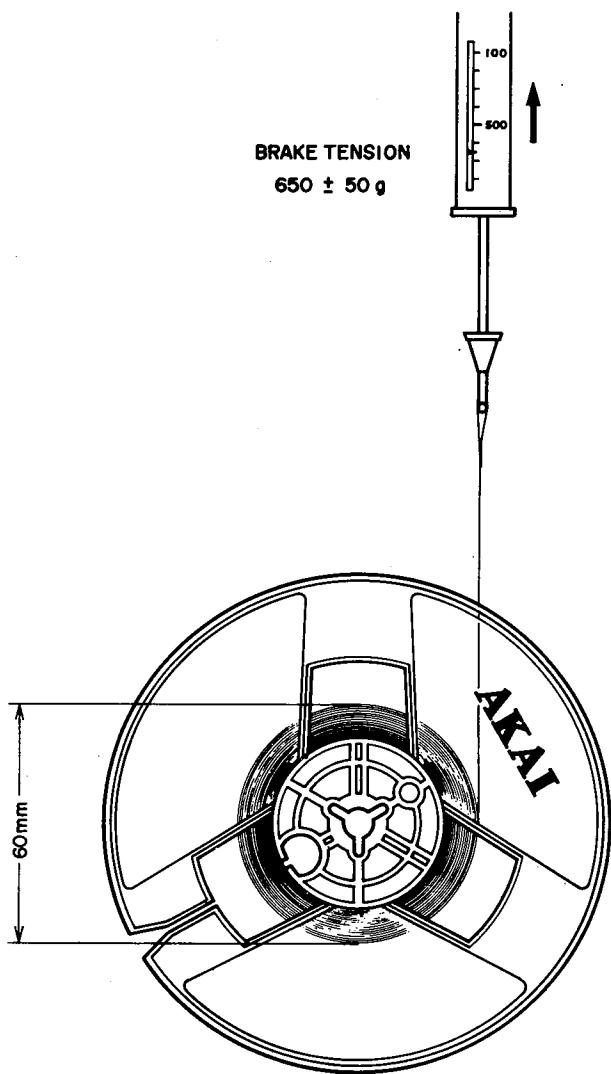

Fig. 7

### 3. BRAKE TENSION ADJUSTMENT

- 1) Brake tension is adjusted using a 5-inch reel to take up 60mm-diameter tape. Measure the tension with a spring scale. Best brake tension is  $650 \pm 50g$ . The difference between both sides should stay within 50g. (Refer to Fig. 7.)
- 2) Here are the ways to adjust brake tension (Refer to Fig. 6).
  - a. Change the position of the suspension spring.
  - b. Adjust the position of the suspension spring metal.

**Note:** After adjusting brake tension, make sure the brake band completely separates from the cross tape of the brake drum by more than 0.5mm for each mode except STOP (Refer to Fig. 6).

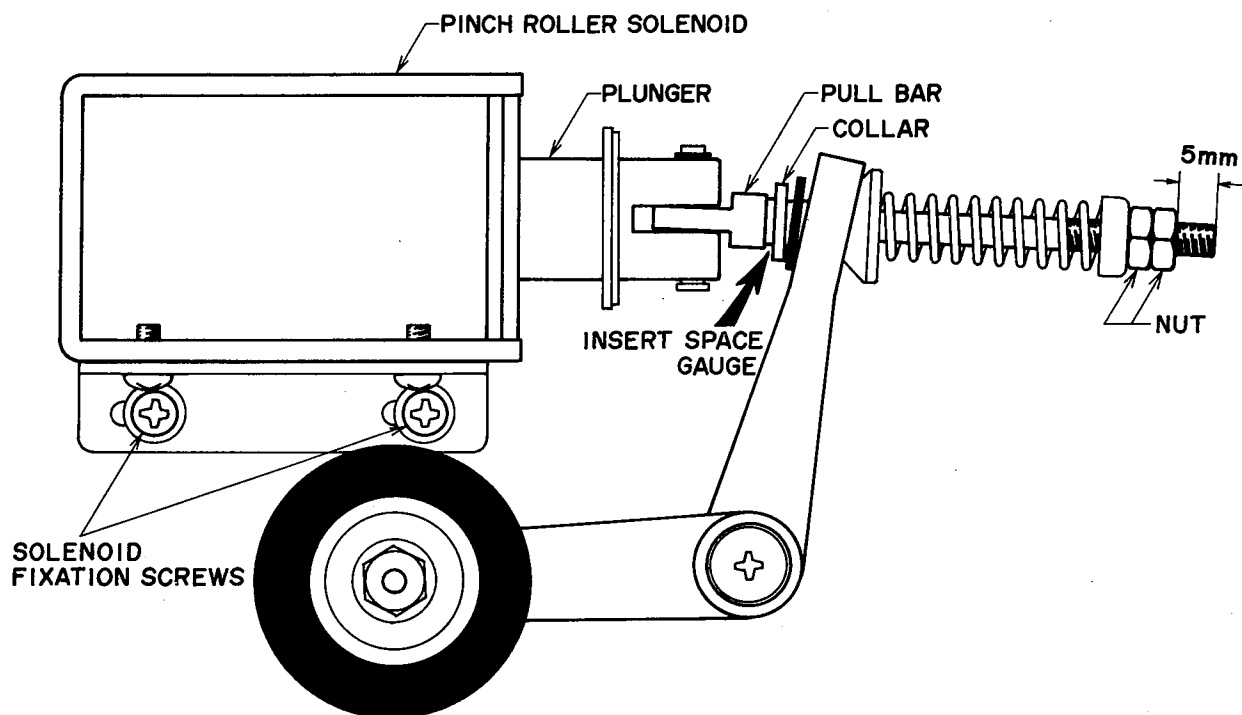
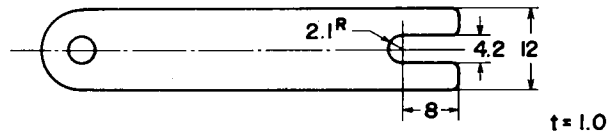

Fig. 8



SPACE GAUGE DIMENSIONS

Fig. 9

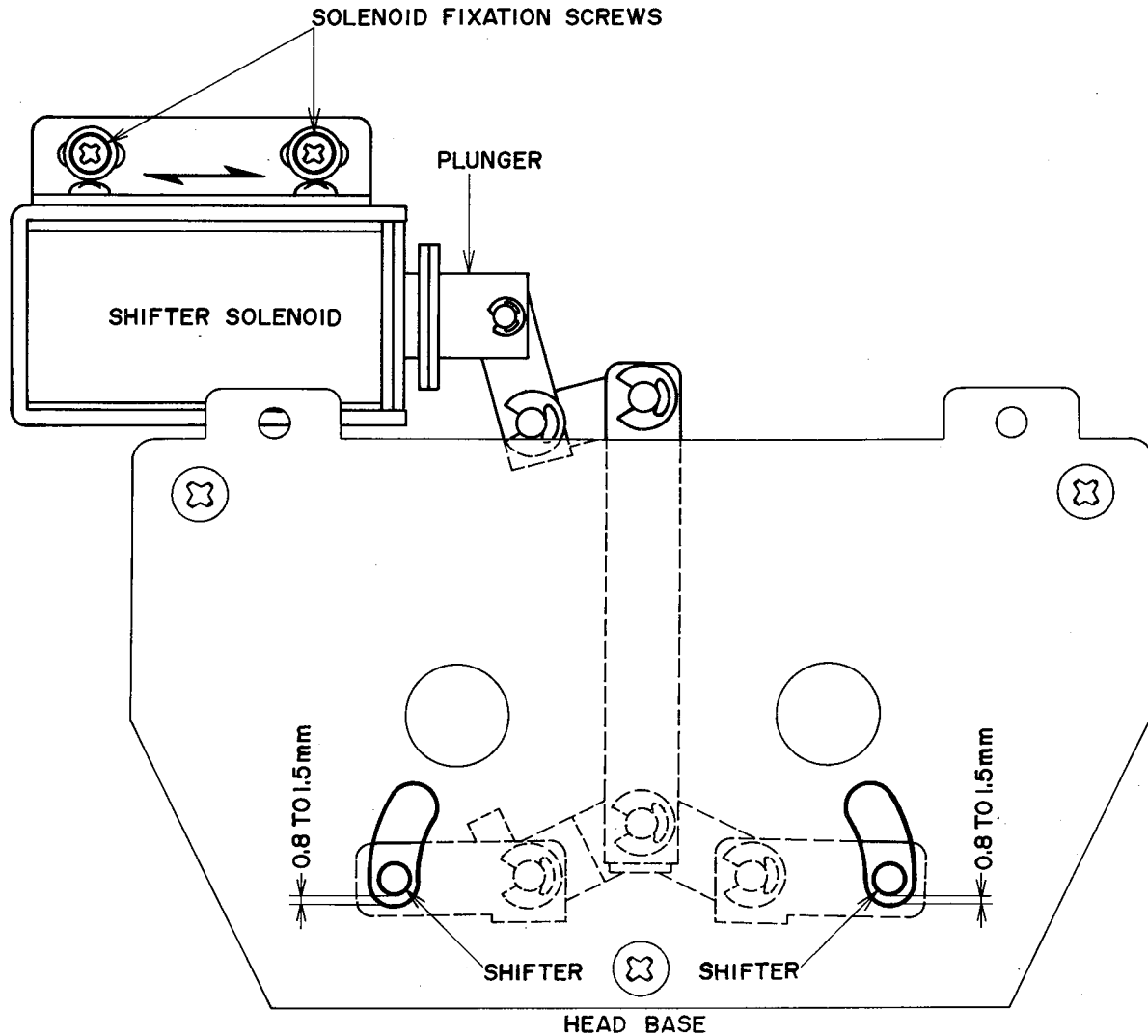

Fig. 10

#### 4. PINCH ROLLER SOLENOID POSITION ADJUSTMENT

Set the nut so that the head of the pullbar screw comes out 5mm from the nut. Insert the space gauge between the collar and pullbar as indicated in Fig. 8 (the size of the gauge is shown in Fig. 9). Fix the solenoid in place when the pinch roller touches the capstan and set both sides equally.

#### 5. SHIFTER SOLENOID POSITION ADJUSTMENT (Refer to Fig. 10)

Adjust the position of the shifter solenoid so that there is a 0.8 – 1.5mm gap between the shifter and the oval hole on the head base when the plunger is pulled. The tape, however, should never touch the head.

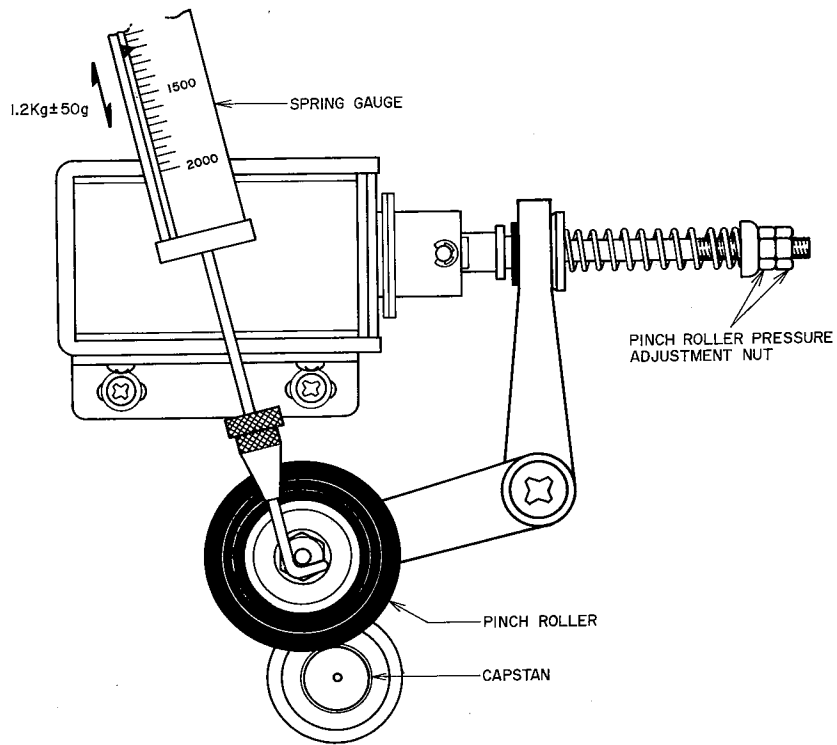

Fig. 11

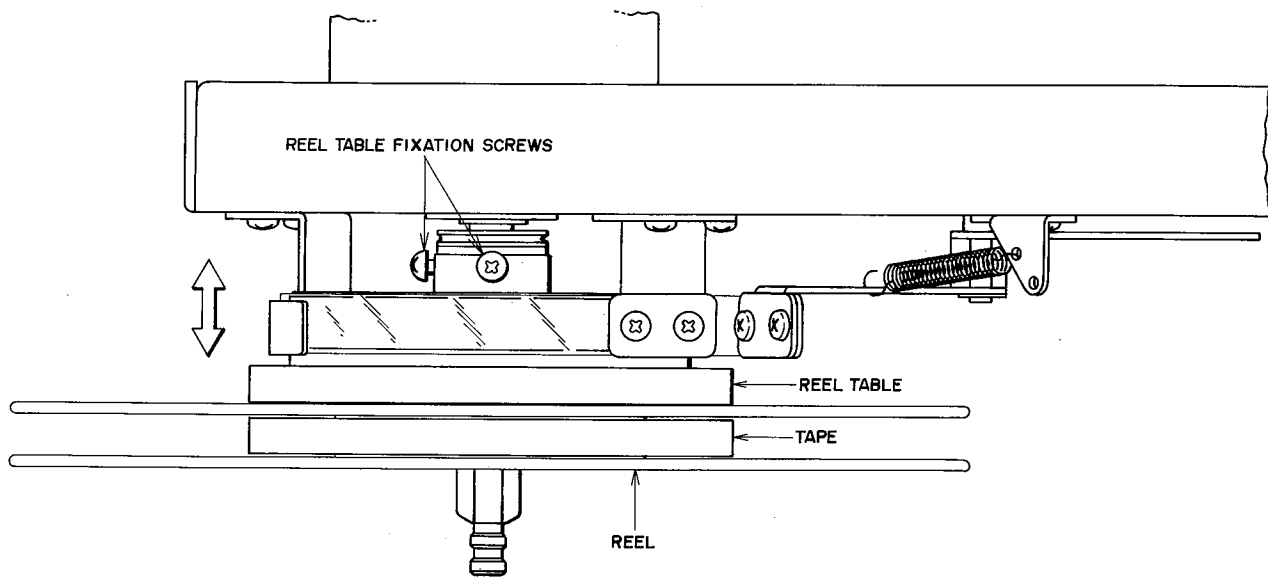

Fig. 12

## 6. PINCH ROLLER PRESSURE ADJUSTMENT (Refer to Fig. 11)

Using the spring scale, pull up the pinch roller, then return it. As the pinch roller touches the capstan during its return, read the indication on the spring scale. At this time, adjust the pinch roller pressure nut so that the spring scale indicates  $1.2\text{kg} \pm 50\text{g}$ .

**Note:** Because this is a dual capstan system, the difference in pinch roller pressure between both sides should be within 50g.

## 7. REEL TABLE HEIGHT ADJUSTMENT (Refer to Fig. 12)

Place the tape on both the left and right reel tables (but not on either tape guide nor on the tension lever). Set the machine on either F.F. or Rew. and adjust the reel table in the direction of the arrow mark so that the tape is taken up in the center of the reel. Tighten the reel table fixing screw at the best position.

**Note:** No matter what type of reel, the tape should always be taken up in the center.

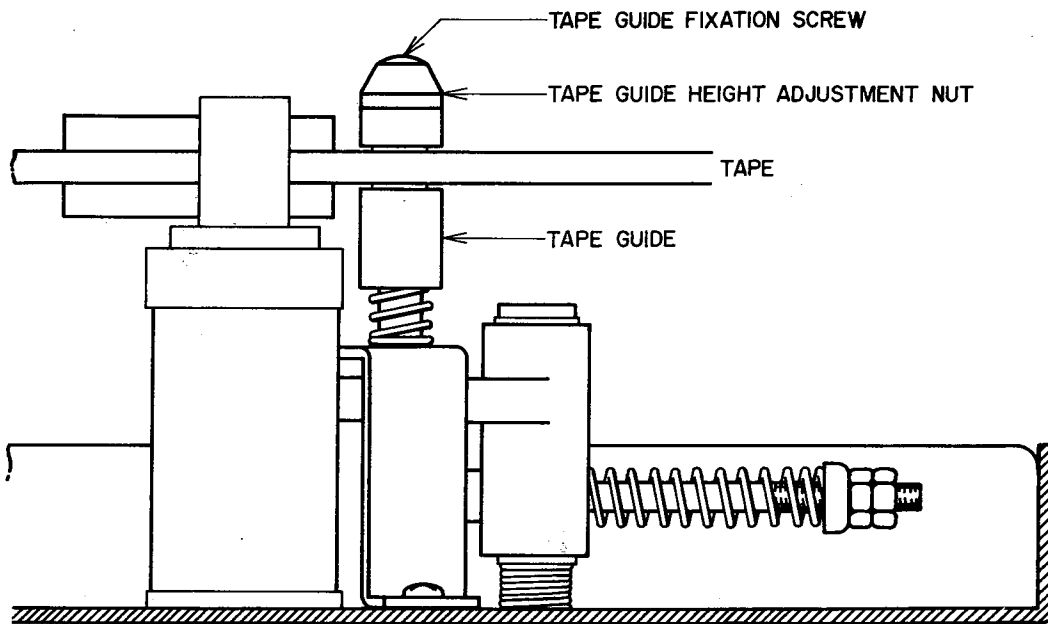

Fig. 13

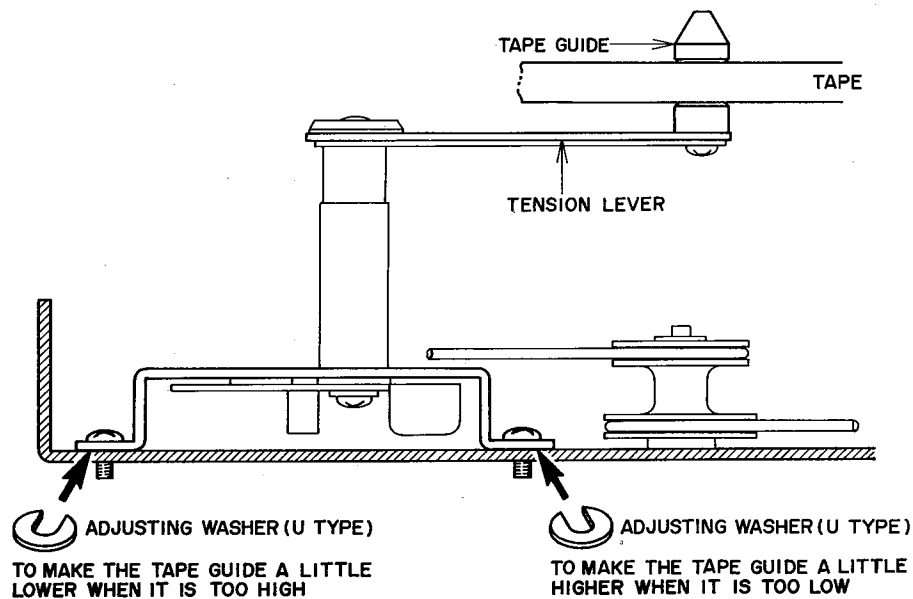

Fig. 14

## 8. TAPE GUIDE HEIGHT ADJUSTMENT

(Refer to Fig. 13)

Place the tape just before the left and right tape guides (but not on either tension lever). Unscrew the tape guide fixing screw and adjust the tape guide height nut so that the tape travels in the center of the guide during FWD. and REV. Tighten the tape guide fixing screw to its normal position.

## 9. TENSION LEVER HEIGHT ADJUSTMENT

(Refer to Fig. 14)

Place the tape on the left and right tension levers (at this time, the tape should be in its proper position on the tape guides). Insert the adjust washer (U type) to adjust the height of the tension lever so that the tape travels in the center of the tape guide during FWD. and REW.

**Note:** Fig. 14 shows the right-hand tape guide. When adjusting the opposite one, the left screw raises it while the right screw lowers it.

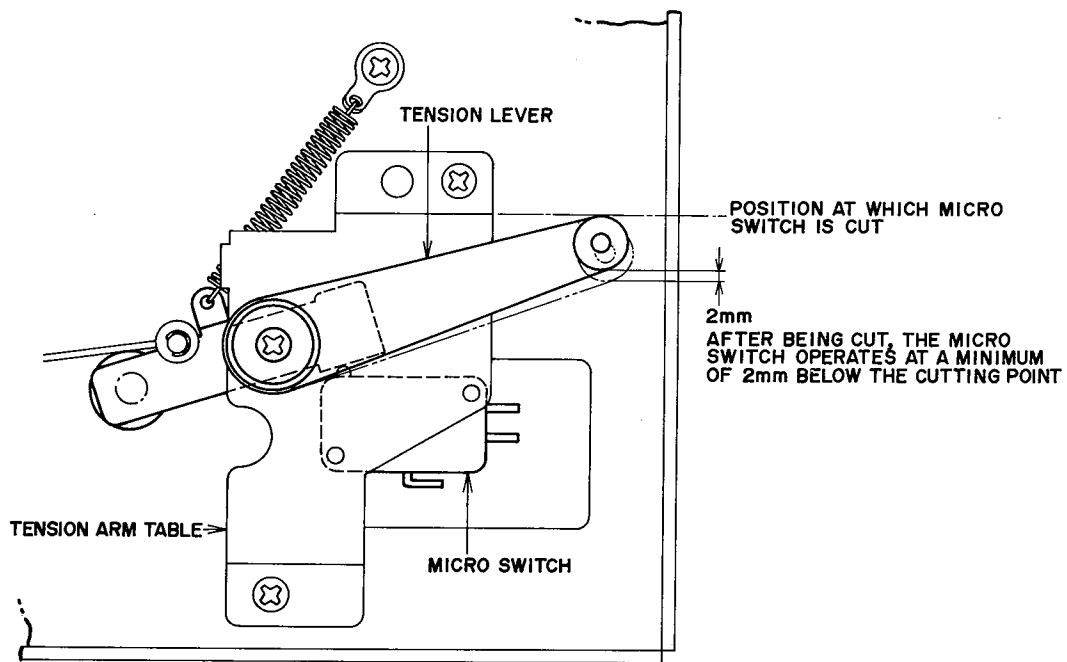

Fig. 15

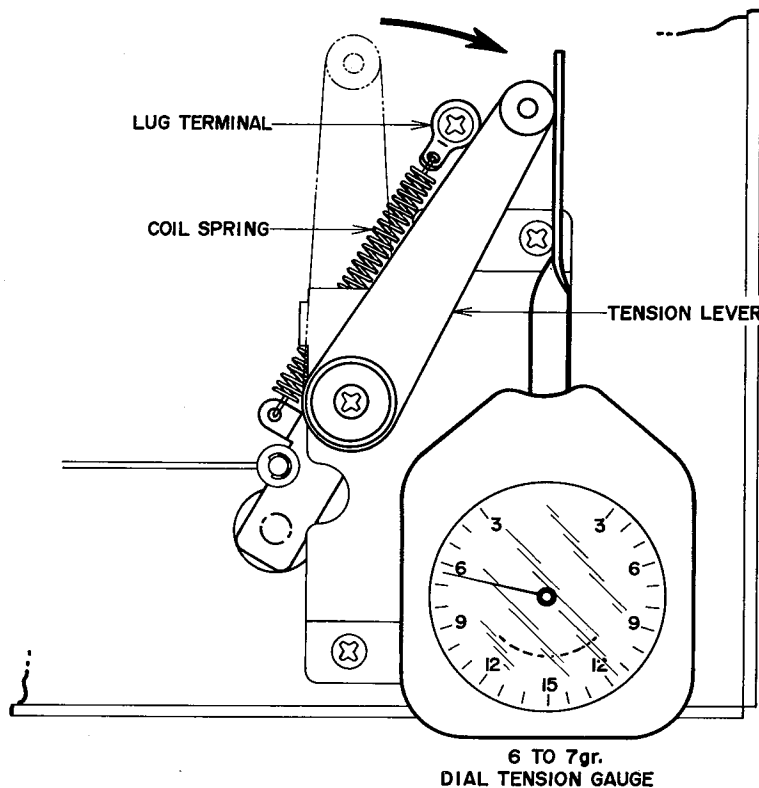

Fig. 16

**10. CONFIRMATION OF BOTH TENSION ARMS OPERATION**

Confirm the operation of each micro switch as illustrated in Fig. 15.

**11. TENSION ARM'S RETURN TENSION ADJUSTMENT (Refer to Fig. 16)**

Bend the lug terminal so that the dial gauge indicates 6 to 7g when the tension arm is returned in the direction of the arrow, mark. This adjusts the strength of the coil spring.

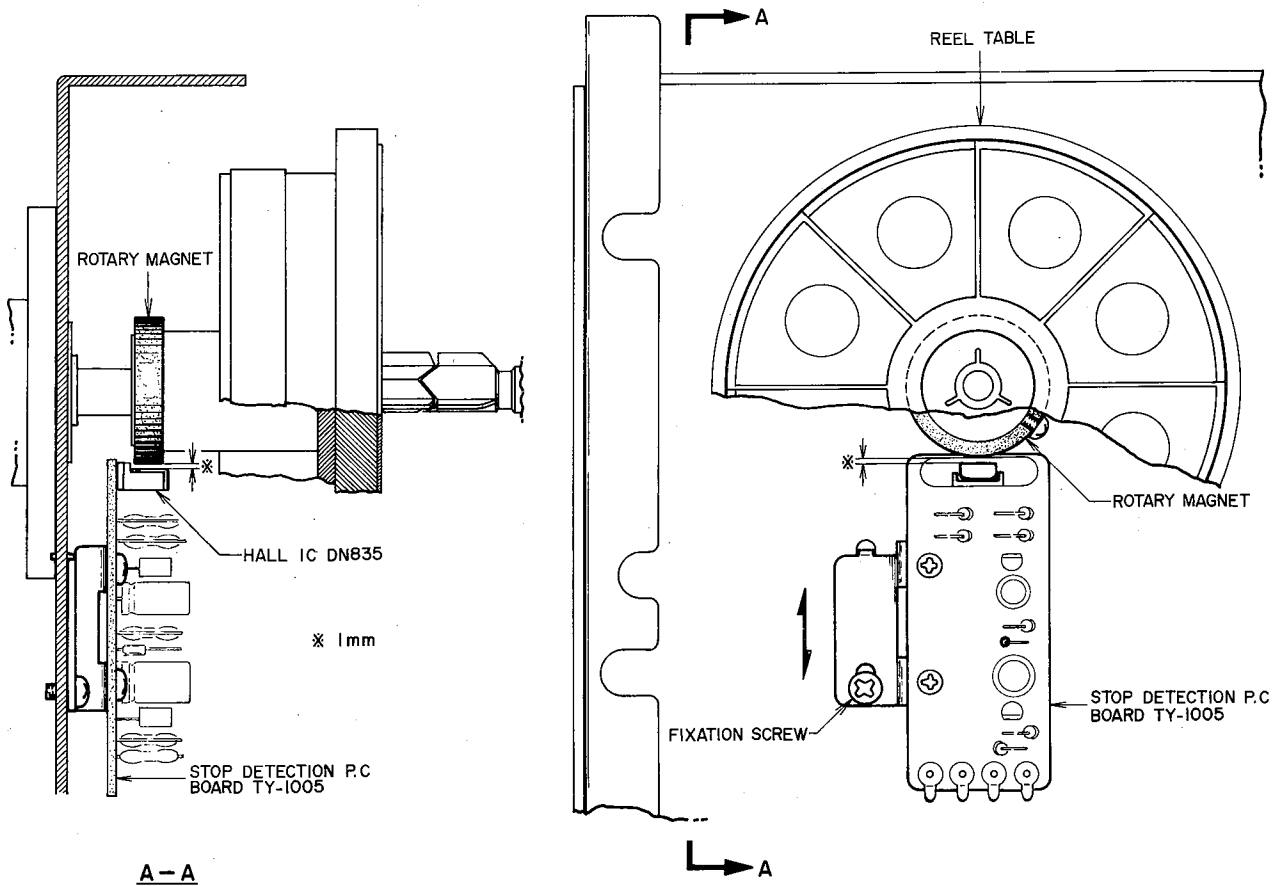

Fig. 17

## 12. GAP ADJUSTMENT OF HOLE IC (DN 835) AND ROTATION MAGNET

(Refer to Fig. 17)

Move the stop detector plate in the direction of the arrow until there is a 1mm gap between the hole IC and rotation magnet.

# IV. HEAD ADJUSTMENT

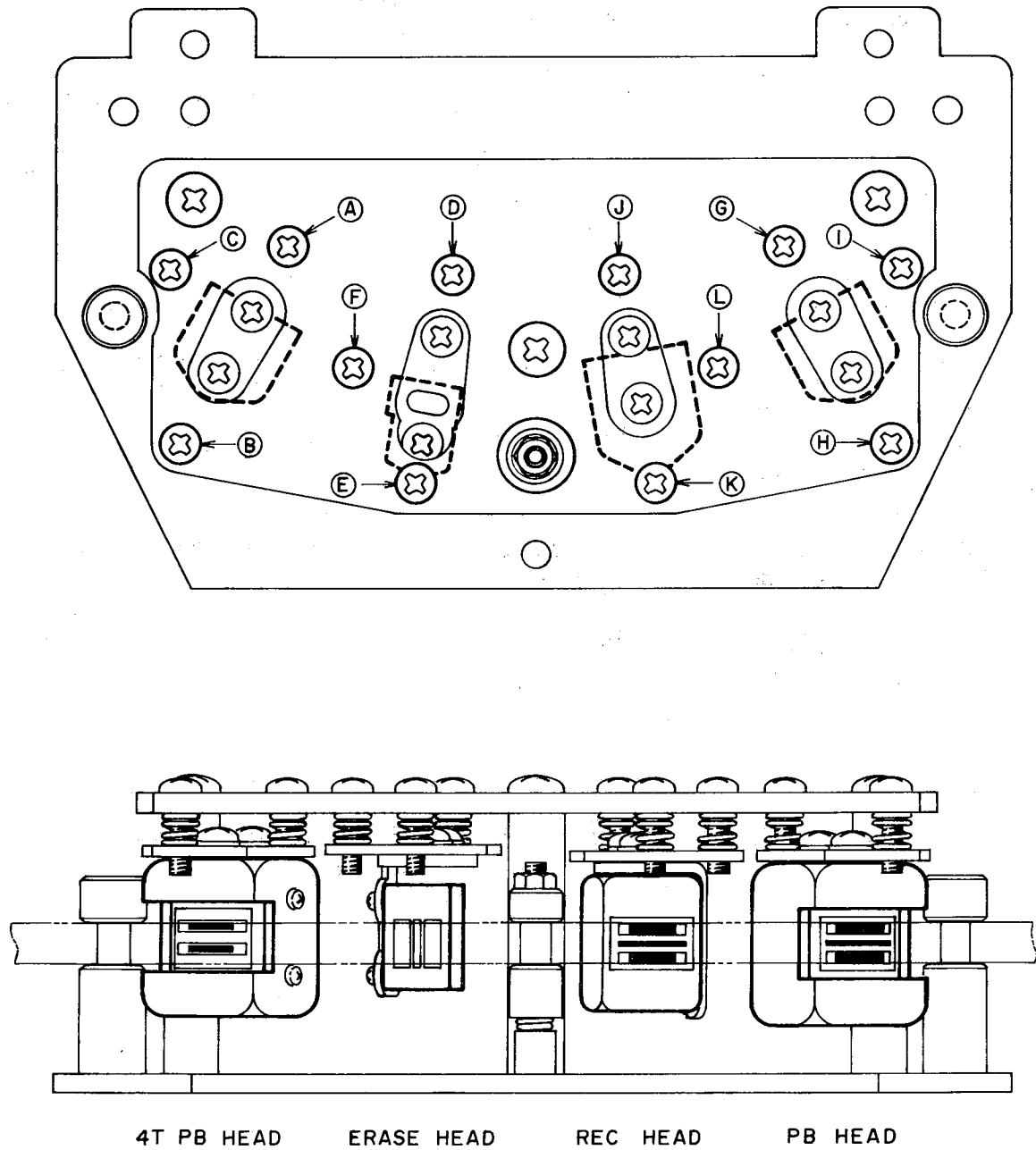

Fig. 18



Step	Adjustment Item	Test Tape or Supply Signal	Mode	Adjustment Point	Remarks
1.	Height of 4-Track Playback Head	Optional	Play	(A) (B) (C)	Make upper edge of Channel 1 head core even with upper edge of tape.
2.	Height of Full-Track Erase Head	Optional	Play	(D) (E) (F)	Set so that equal portions of head core are visible from top and bottom edge of tape.
3.	Height of Two-Track Recording Head	Optional	Play	(J) (K) (L)	Set upper edge of Channel 1 head core even with upper edge of tape.
4.	Height of Two-Track Playback Head	Optional	Play	(G) (H) (I)	Set upper edge of Channel 1 head core even with upper edge of tape.
5.	Azimuth Alignment of Four-Track Playback Head	15,000Hz/ 38cm/sec Test Tape	4-Track Play	(C)	Maximum Output of Both Channels
6.	Azimuth Alignment of Two-Track Recording Head	15,000Hz/ 38cm/sec Test Tape	2-Track Play	(I)	Maximum Output of Both Channels
7.	Azimuth Alignment of Two-Track Recording Head	15,000Hz -20dB Signal	2-Track Play	(L)	Maximum Output of Both Channels

# V. AMPLIFIER ADJUSTMENT

VR1 1KB Supply Voltage Adj. 30.0V

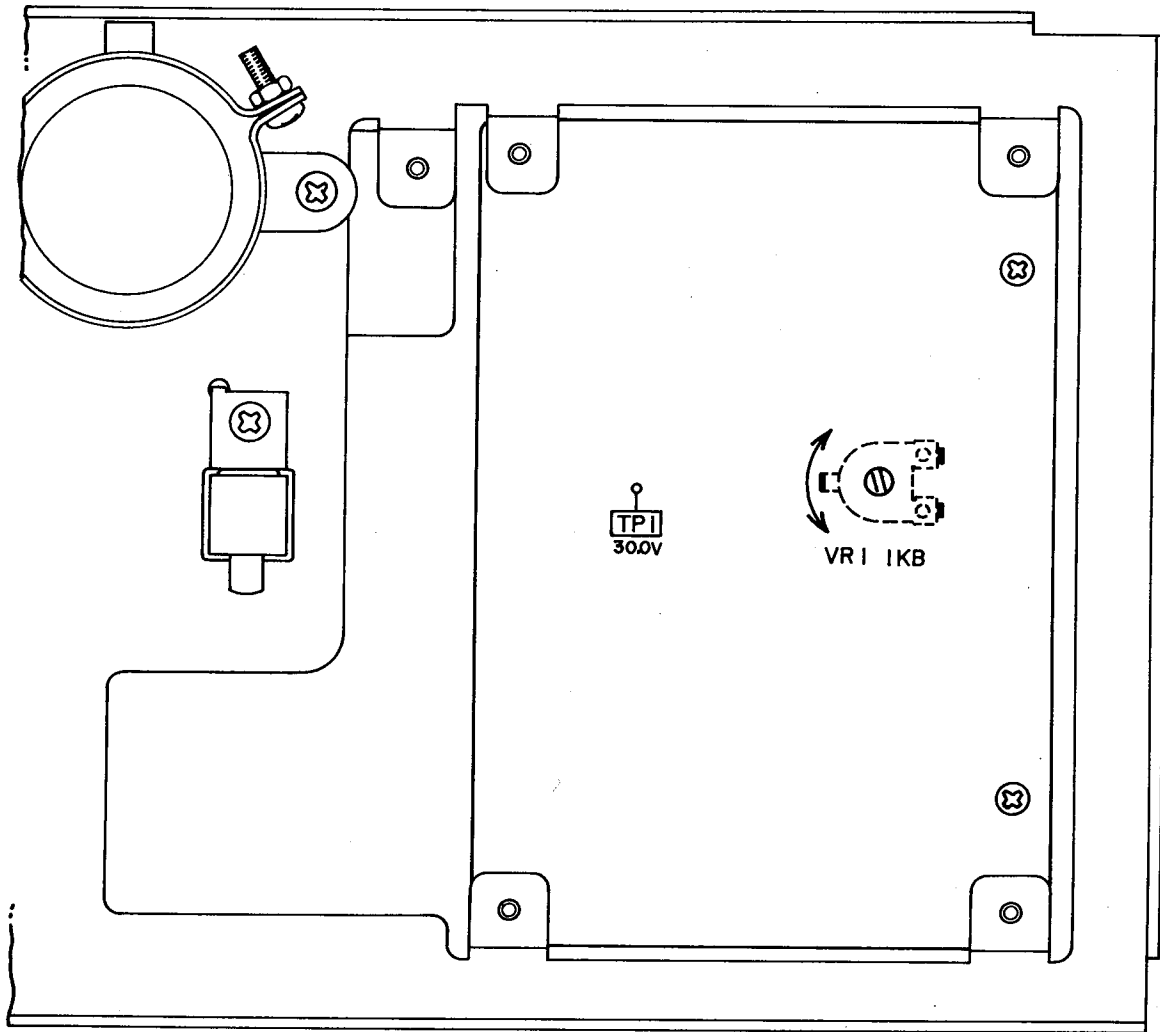

Fig. 19 Power Supply P.C Board TV-5020

## 1. POWER SUPPLY VOLTAGE

### ADJUSTMENT (Refer to Fig. 19)

Adjust the semi-fixed volume VR1 1KB so that the TP1 terminal becomes 30.0V.

VR1	1KB	Servo Circuit Voltage Adj.	21.0V
VR2	5KB	Tape Speed Adj.	38cm/sec
VR3	10KB	Tape speed Adj.	19cm/sec
VR4	30KB	Tape Speed Adj.	9.5cm/sec

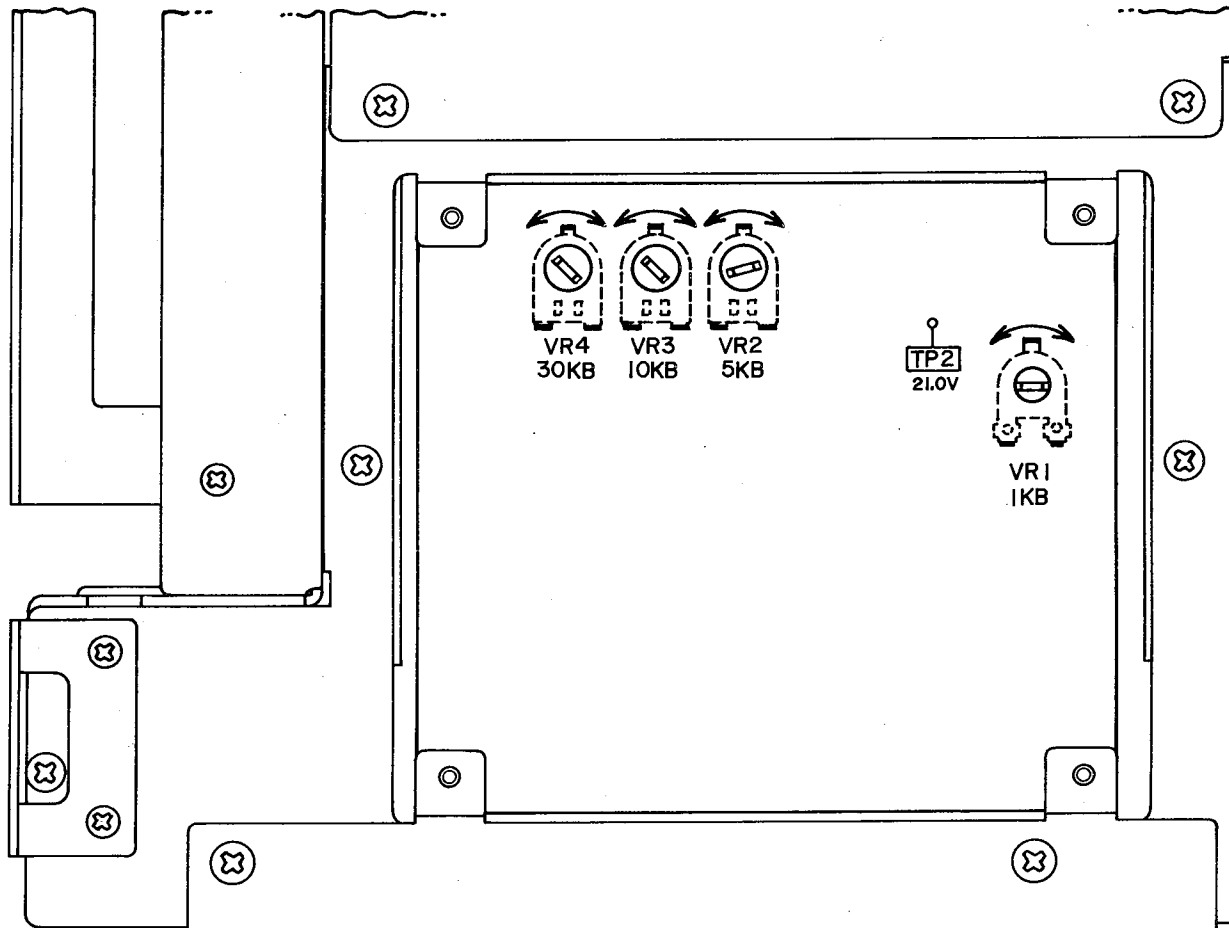

Fig. 20 Servo P.C Board TW-1049 (5ED)

## 2. SERVO CIRCUIT VOLTAGE

### ADJUSTMENT (Refer to Fig. 20)

Adjust the semi-fixed volume VR1 1KB so the TP2 terminal becomes 21.0V.

## 3. TAPE SPEED ADJUSTMENT

### (Refer to Fig. 20)

Playback the 1,000Hz/19cm/sec. tape speed adjustment tape and adjust each tape speed.

38cm/sec.	2,000Hz $\pm$ 0.5%
19cm/sec.	1,000Hz $\pm$ 0.5%
9.5cm/sec.	500Hz $\pm$ 0.5%

## 4. PLAYBACK AND RECORDING

### AMPLIFIER ADJUSTMENT

Prior to adjustment, set each selector and control as follows.

- 1) PB Head (2-track, 4-track)  $\rightarrow$  2-track
- 2) Equalizer (38, 19, 9.5)  $\rightarrow$  38
- 3) Meter Selector (Bias Check, Peak, VU)  $\rightarrow$  VU
- 4) Monitor (Tape, Source)  $\rightarrow$  Tape
- 5) Playback Out  $\rightarrow$  0VU (Center)
- 6) Input 1, Input 4  $\rightarrow$  Optional
- 7) Input 2, Input 3  $\rightarrow$  Minimum
- 8) Master Volume  $\rightarrow$  Maximum
- 9) Phone Level  $\rightarrow$  Optional
- 10) Input 1, Input 4 Selector  $\rightarrow$  Line
- 11) Input 2, Input 3 Selector  $\rightarrow$  ATT (20dB)
- 12) Pan  $\rightarrow$  Center
- 13) Bias, EQ  $\rightarrow$  Center

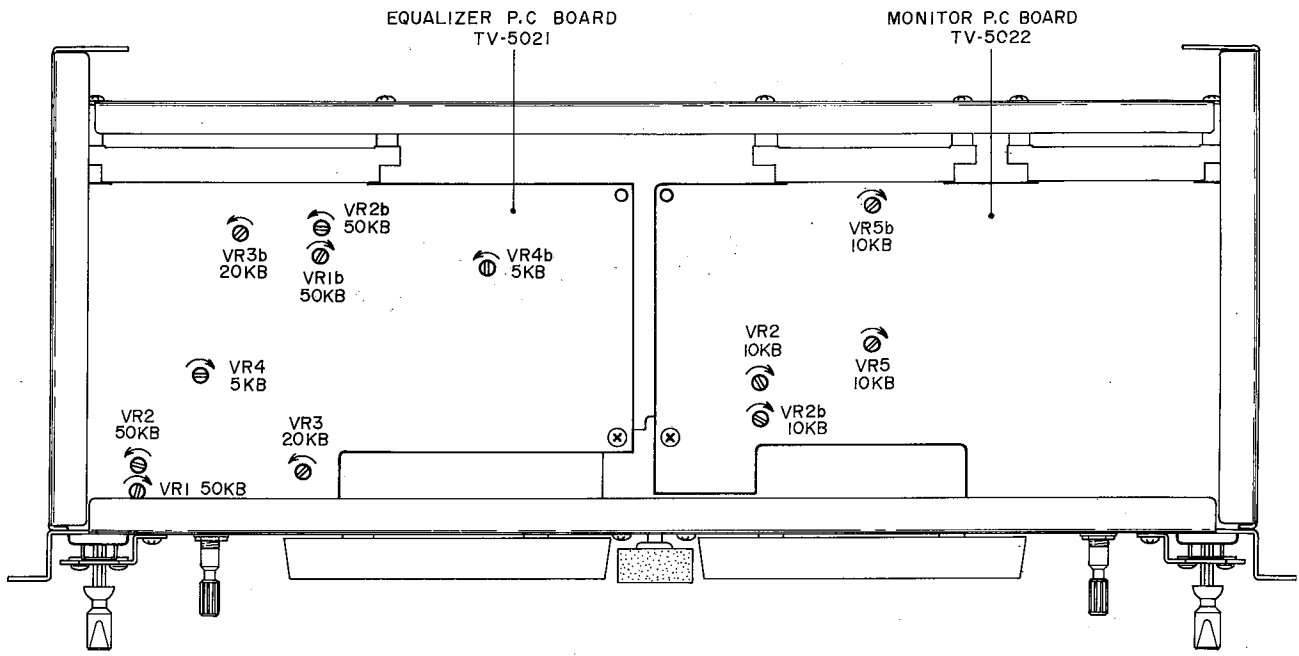

Fig. 21 Amp. Block Top View

Equalizer P.C Board TV-5021

- VR1 2-track PB Level Adj.
- VR2 4-track PB Level Adj.
- VR3 PB Equalizer Adj.
- VR4 ADR Adj.

Monitor P.C Board TV-5022

- VR2 Peak Meter Adj. (-10VU)
- VR5 Peak Meter Adj. (-30VU)

\* Parts bearing the letter "b" after the semi-fixed volume part number are for the right channel.

Example: VR1 50KB Left Channel  
 VR2b 50KB Right Channel

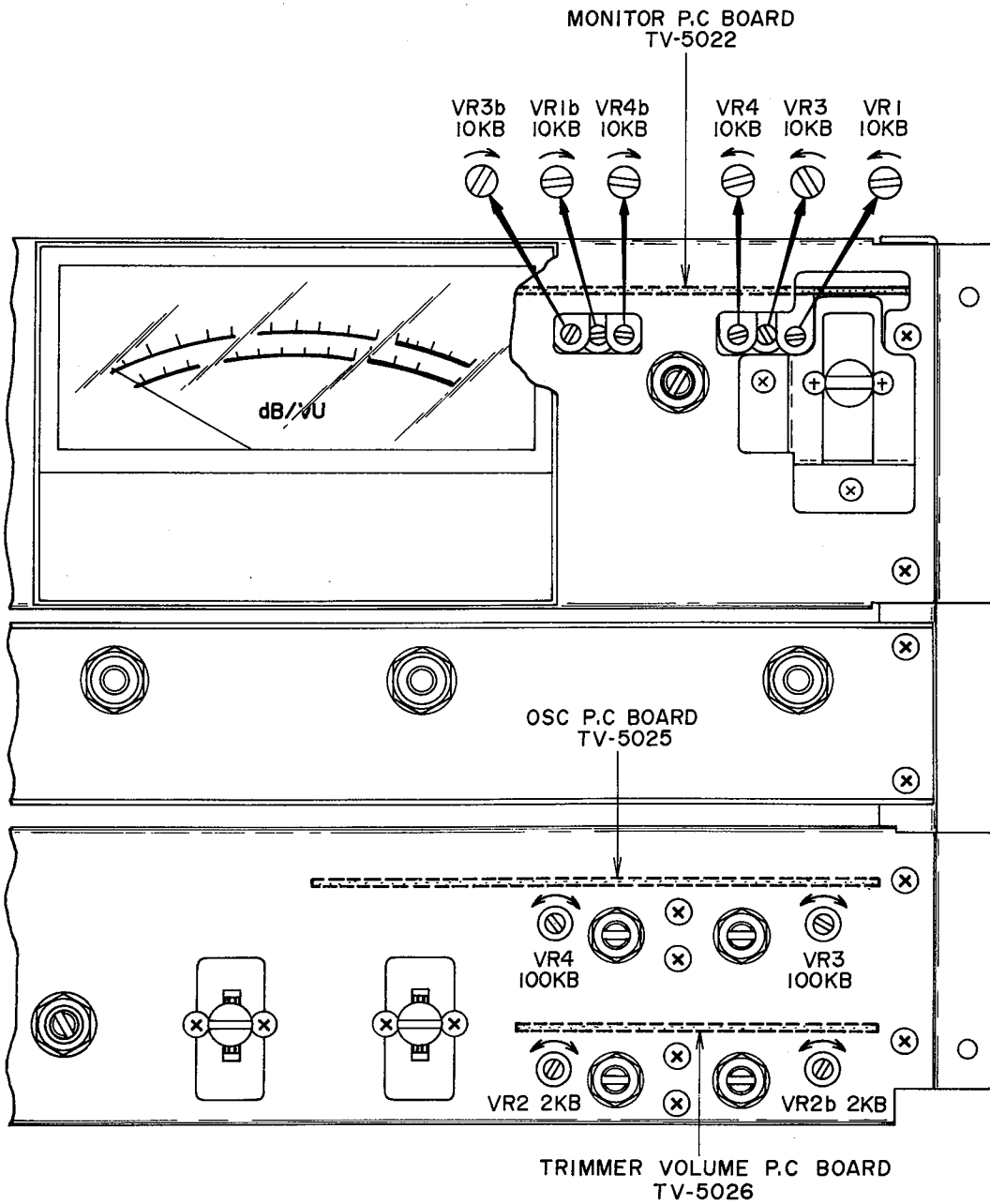

Fig. 22 Amp. Block Front View

Monitor P.C Board TV-5022

- VR1 Peak Meter Adj. (0 VU)
- VR3 VU Meter, 0 VU Adj.
- VR4 Bias Check, "0" Indication Adj.

Bias Oscillator P.C Board TV-5025

- VR3 Recording Bias Adj. (Right Channel)
- VR4 Recording Bias Adj. (Left Channel)

Trimmer Volume P.C Board TV-5026

- VR2 Recording Equalizer Adj.

\* Parts bearing the letter "b" after the semi-fixed volume part number are for the right channel.

- Example: VR1 10KB Left Channel
- VR1b 10KB Right Channel

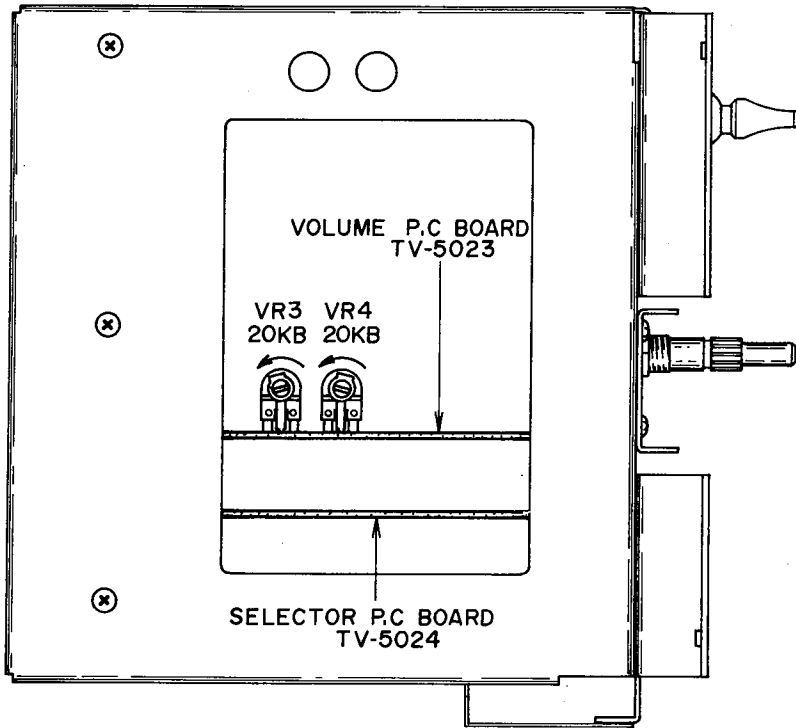

Volume P.C Board TV-5023  
 VR3 Recording Level Adj.  
 VR4 Mixing Output Adj.

Fig. 23 Amp. Block Left Side View

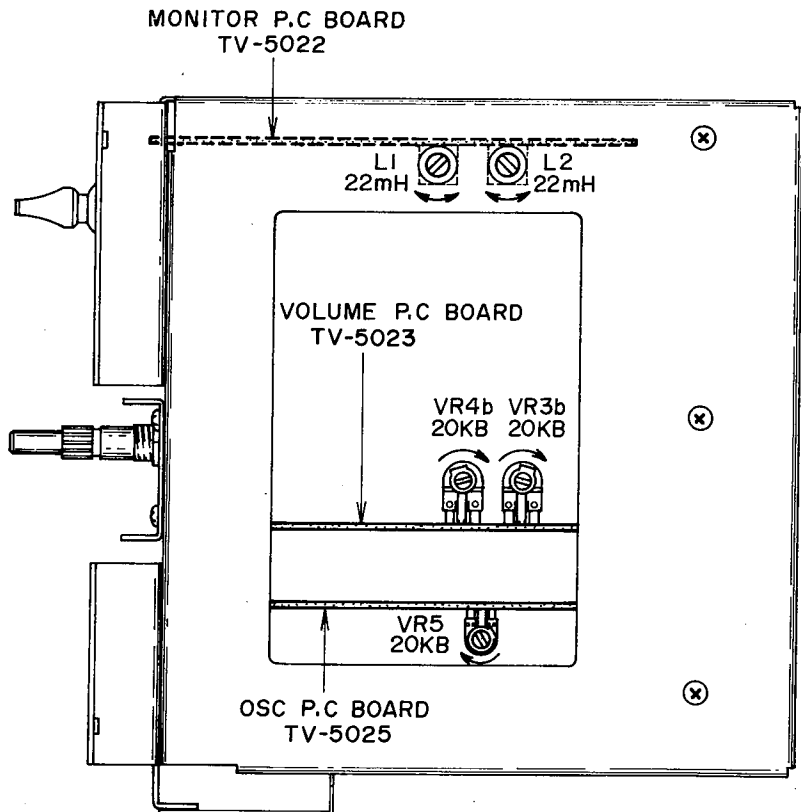

Volume P.C Board TV-5023  
 VR3b Recording Level Adj.  
 (Right Channel)  
 VR4b Mixing Output Adj.  
 (Right Channel)  
 Bias Oscillator P.C Board TV-5025  
 VR5 Erase Current Adj.  
 Monitor P.C Board TV-5022  
 L1 Bias Leak Adj. (Left Channel)  
 L2 Bias Leak Adj. (Right Channel)

Fig. 24 Amp. Block Right Side View

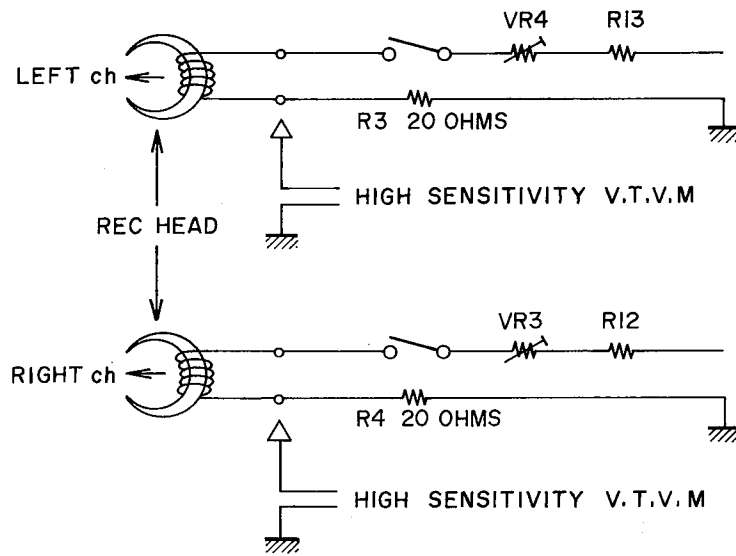

Fig. 25 ADR Test Terminal

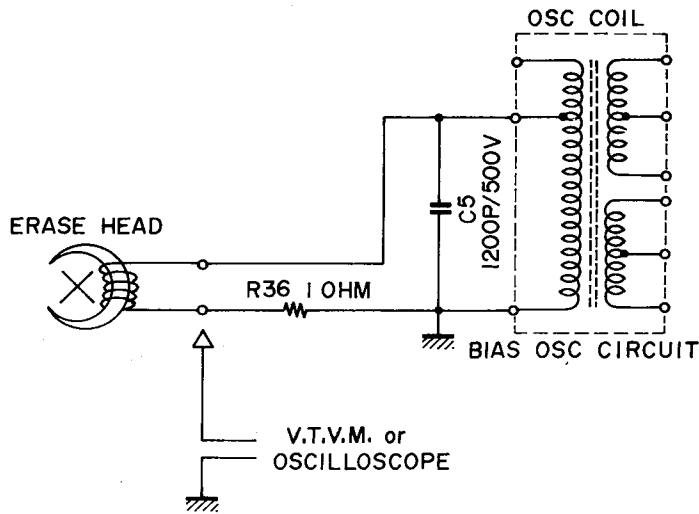

Fig. 26 Erase Current Test Terminal

\* When using an AC voltmeter, use one with an input impedance of more than 10M OHMS and an input capacity of less than 25 PF.  
 Example: National VP-960A  
 If an oscilloscope is used, the peak figure will be indicated.

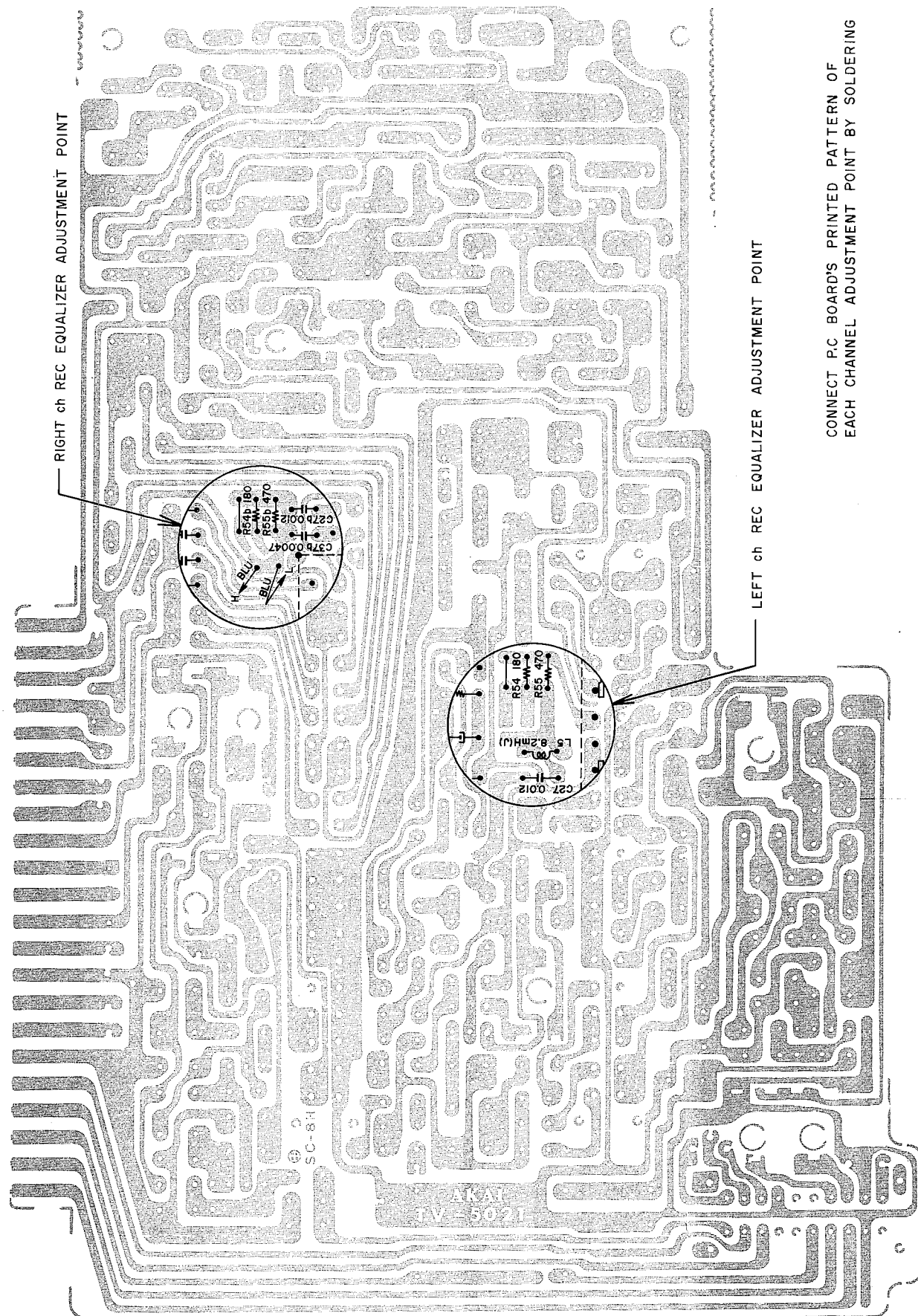

Fig. 27 Rec. Equalizer Peaking Adjustment (9.5cm/sec.)



Step	Adjustment Item	Test Tape/ Supply Signal	Mode	Adjustment Point	Result	Remarks	Reference Figure
1	2-Track Playback Level	700Hz/38cm/sec. 0 VU Tape	2-Track Play	VR 1 50KB EQ P.C Board	0dBs (0.775V)		Fig. 21
2	4-Track Playback Level	700Hz/38cm/sec 0 VU Tape	4-Track Play	VR2 50KB EQ P.C Board	0dBs (0.775V)		Fig. 21
3	Playback Equalizer	15,000Hz/38cm/ sec. 0 VU Tape	2-Track Play	VR 2 5KB EQ P.C Board	0dBs (0.775V)		Fig. 21
4	Mixing Level	1,000Hz line input, 0 dBs line output	Stop	VR 4 20KB Volume P.C Board	300 mV Mixing Output Terminal	Switch monitor switch to Source	Fig. 23,24
5	A. D. R.	1,500Hz, 15,000Hz line input, 0 dBs line output	REC	VR 3 20KB EQ P.C Board	7 dB above the 15,000Hz level	Tape Speed at 9.5cm/sec, monitor switch at source	Fig. 21,25
6	Erase Current		REC	VR 5 20KB OSC P.C Board	100mVrms 283mVP-P	Peak figure indication $= 100mV \times 2\sqrt{2}$	Fig. 24,26
7	REC Bias (Frequency Characteristics)	Scotch #206 Tape 2,000Hz, 20kHz -20 VU Recording	REC	VR 3 100KB VR 4 100KB OSC P.C Board	Flat Charac- teristics at 2,000Hz, 20kHz	Bias, Equalizer Adjustment Center Tape Speed at 19cm/sec refer to NOTE	Fig. 22
8	REC Level	Scotch #206 Tape 1,000Hz 0VU Recording	REC	VR 3 20KB Volume P.C Board	0dBs $\pm$ 0.7dB (0.775V)	Tape Speed at 19cm/sec	Fig. 23,24
9	Bias Check "0" Indication		REC	VR 4 10KB Monitor P.C Board	Needle "0" Indication	Performed after recording bias adjustment. Set the meter Selector at bias Check.	Fig. 22
10	VU Meter Indication	1,000Hz line input, 0dBs line output	Stop	VR 3 10KB Monitor P.C Board	0 VU	Monitor Switch at Source, Meter Selector at VU	Fig. 22
11	Peak Meter Indication	1,000Hz line input, 8dBs line output	Stop	VR 1 10KB Monitor P.C Board	0 VU	Monitor Switch at Source, Meter Selector at PEAK	Fig. 22
12		1,000Hz line input, -2dBs line output	Stop	VR 2 10KB Monitor P.C Board	-10VU		Fig. 21
13		1,000Hz line input, -22dB line output	Stop	VR 5 10KB Monitor P.C Board	-30VU		Fig. 21

Step	Adjustment Item	Test Tape/ Supply Signal	Mode	Adjustment Point	Result	Remarks	Reference Figure
14	Bias Leak		REC	L1 22mH Monitor P.C Board	less than -40dBs	Rec. volume 1 to 4: Minimum Master volume: Minimum, Monitor Switch at Source	Fig. 24

Note: After Rec bias adjustment, check the frequency characteristic of each tape speed.

38cm/sec 50 - 20,000Hz  $\pm$  1dB

19cm/sec 40 - 24,000Hz  $\pm$  3dB

9.5cm/sec 60 - 12,000Hz  $\pm$  3dB

If the frequency characteristic at 9.5cm/sec is not up to standard, adjust the peak figure of the recording equalizer on the EQ P.C Board. (Refer to Fig. 27 Schematic Diagram)

# VI. COMPOSITION OF VARIOUS P.C BOARDS

## 1. SELECTOR P.C BOARD TV-5024

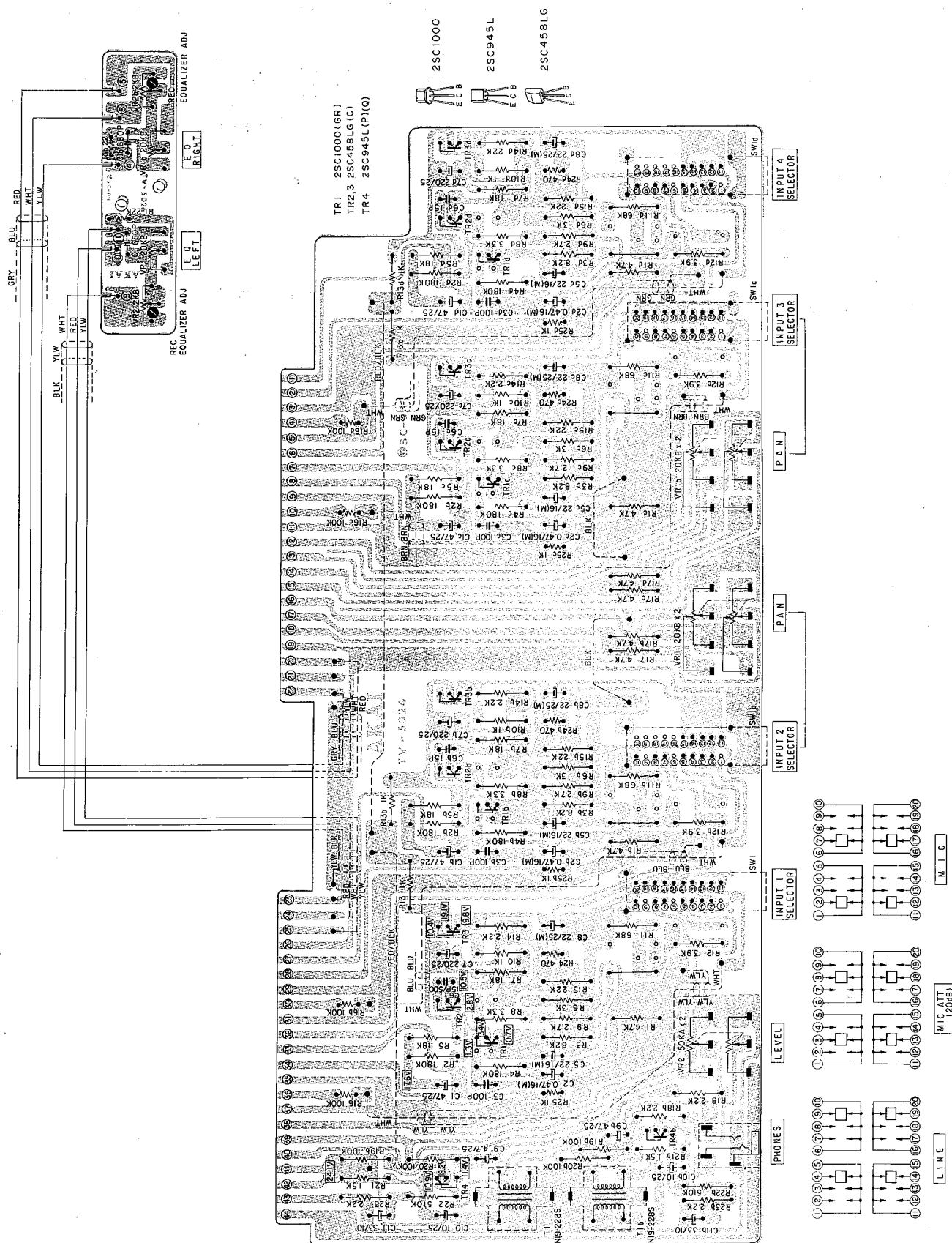

2. VOLUME P.C BOARD TV-5023

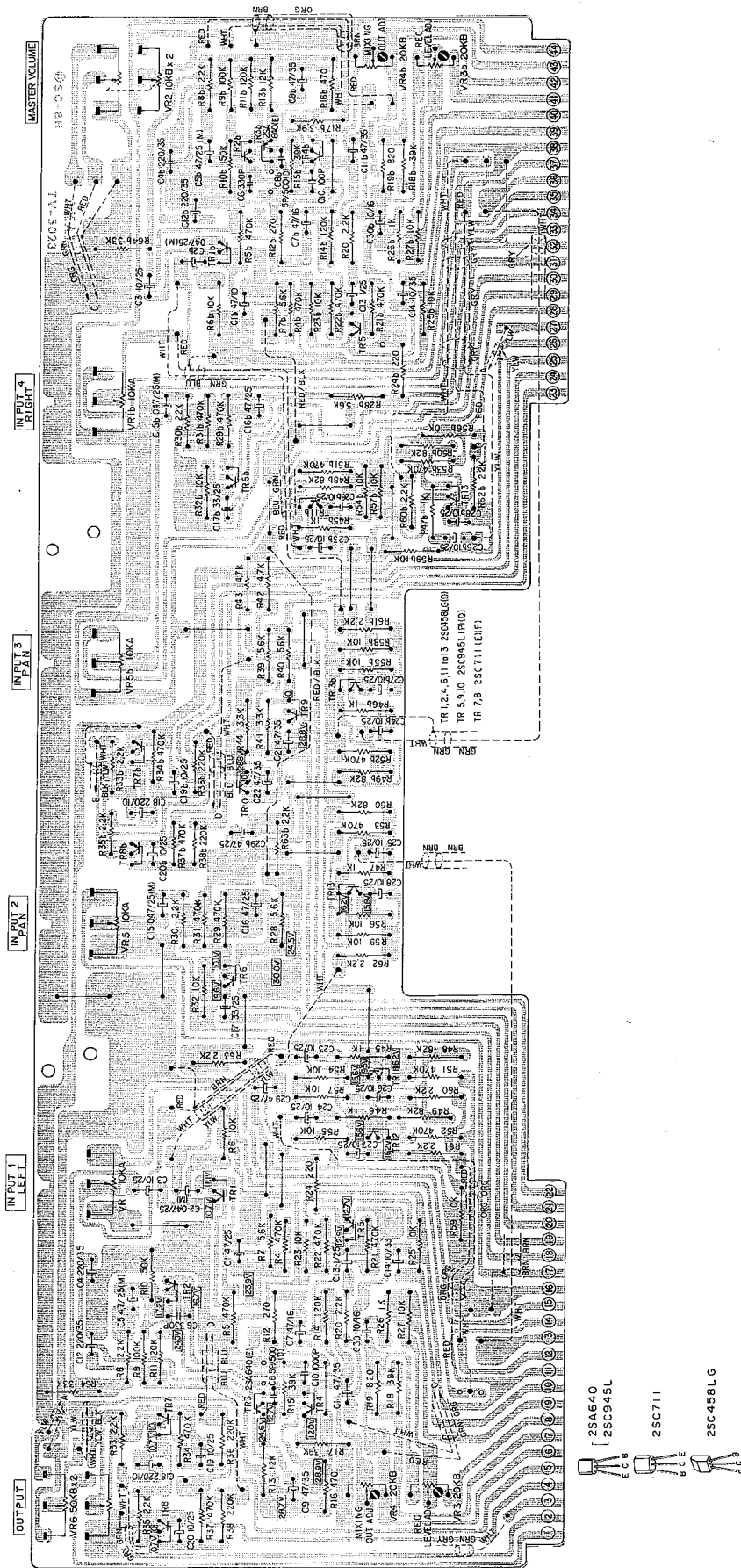

# 3. EQUALIZER P.C BOARD TV-5021

25C458L

25C945L  
25A733  
25C1247A

25K30A

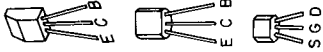

TR1,6 25C458L(G)(D) TR5 25C1247A(V)(B)  
TR3, 25C945L(P)(Q) TR7 25K30A(D)  
TR4, 25A733(P)(Q)

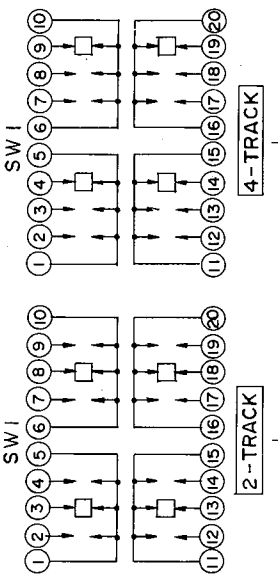
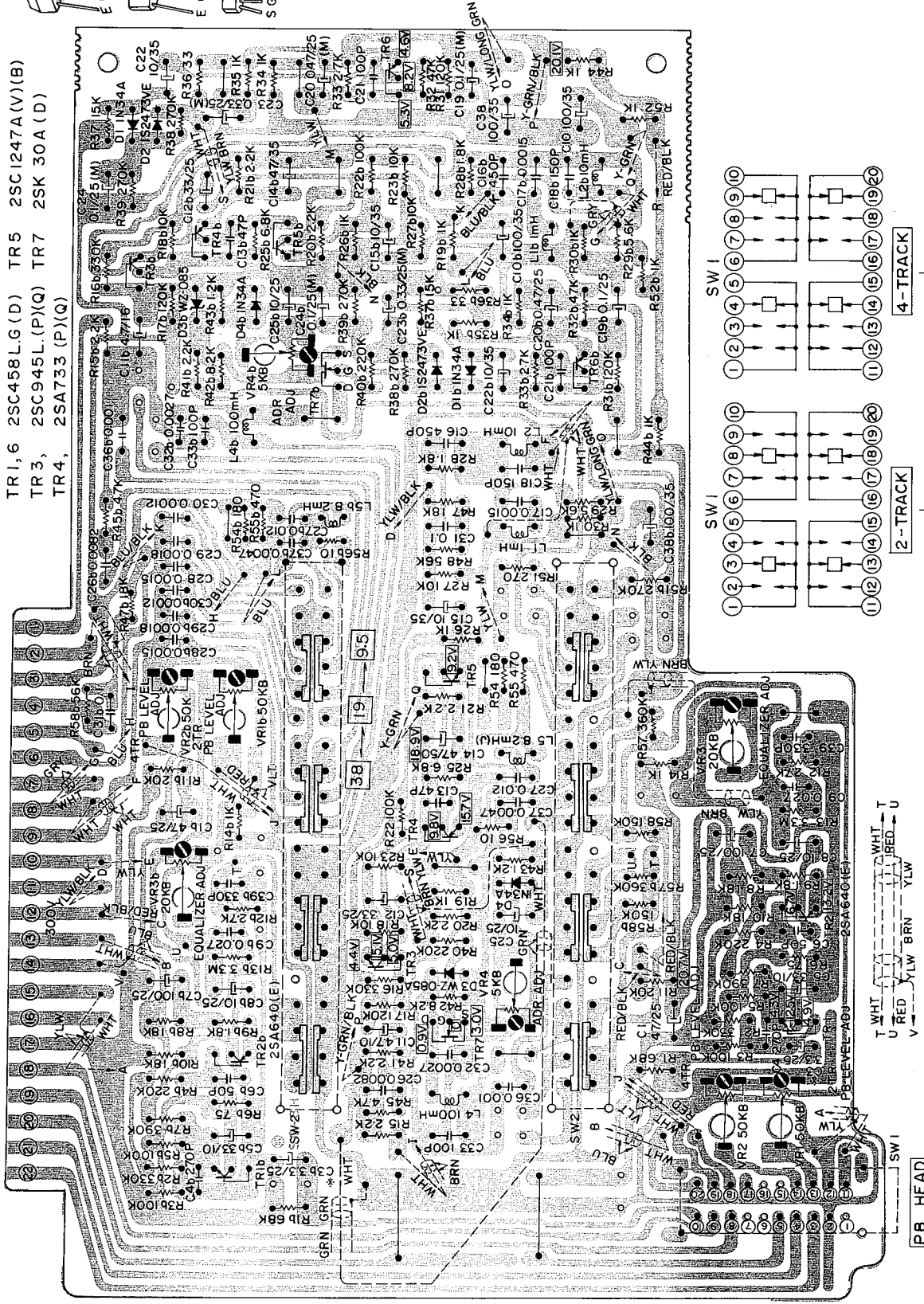

PB HEAD

2-TRACK

4-TRACK



PB HEAD

# 4. MONITOR P.C BOARD TV-5022

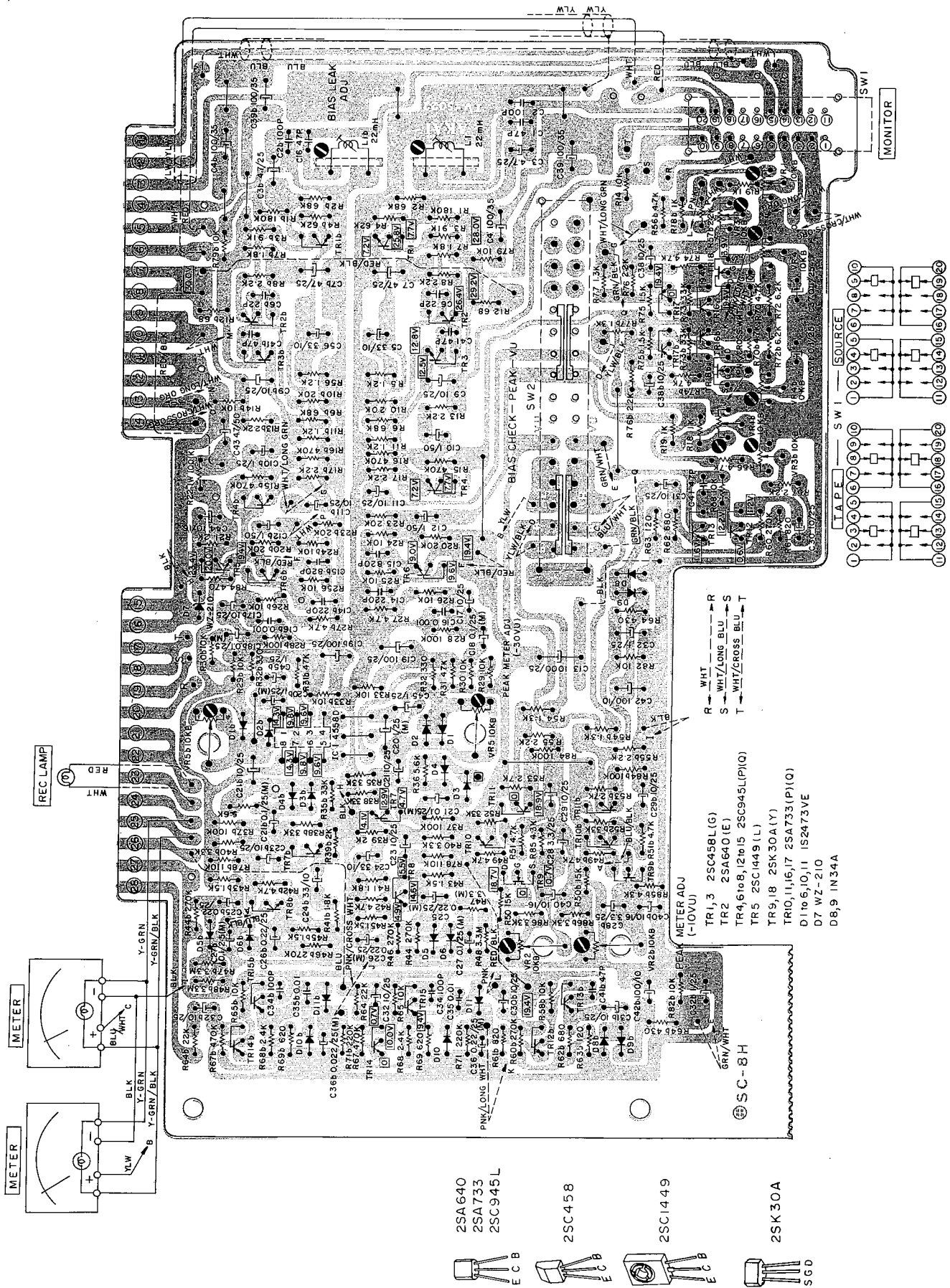

5. OSC P.C BOARD TV-5025

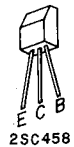
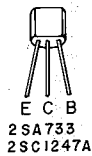
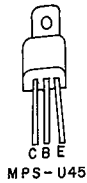
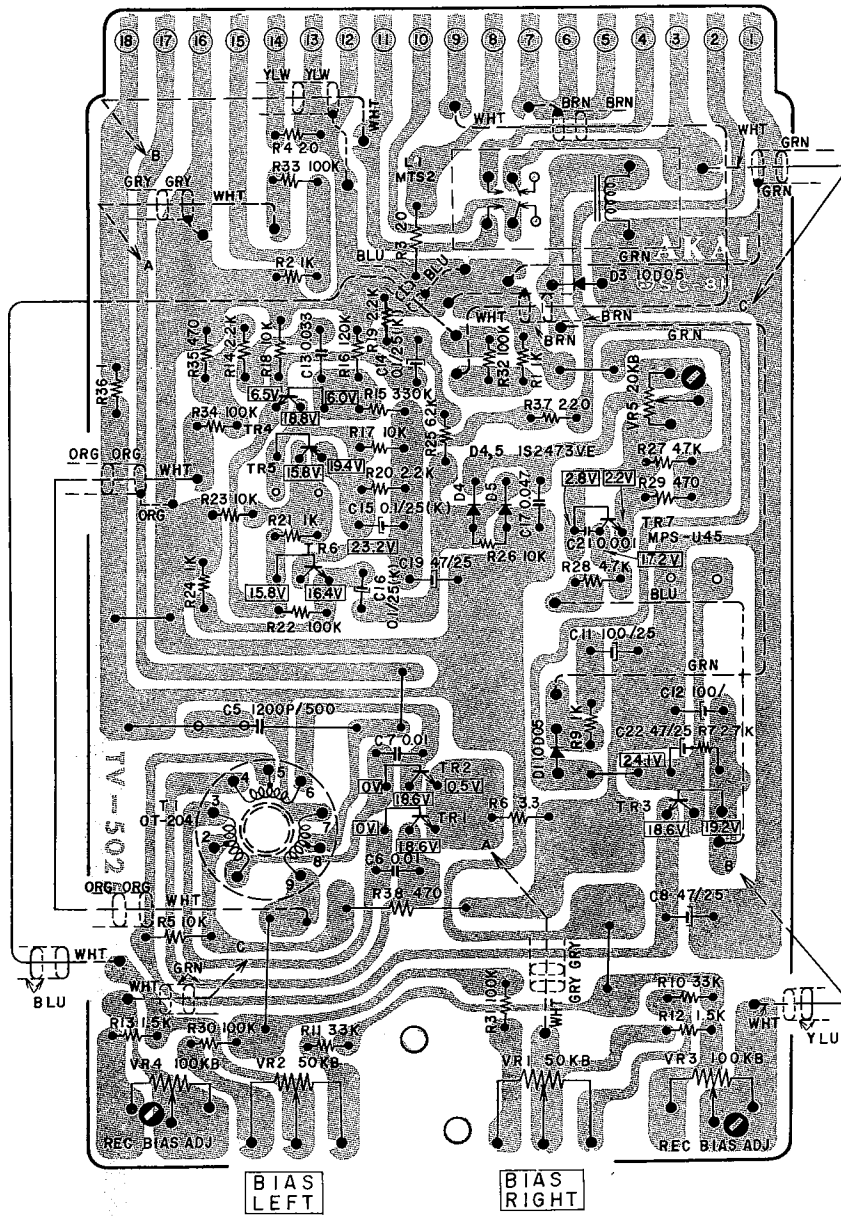

- TR 1, 2 2SC1247A(B)(V)
- TR 4, 6 2SC458 (C)
- TR 5 2SA733(P)(Q)

# 6. MODE SWITCH P.C BOARD TV-1005

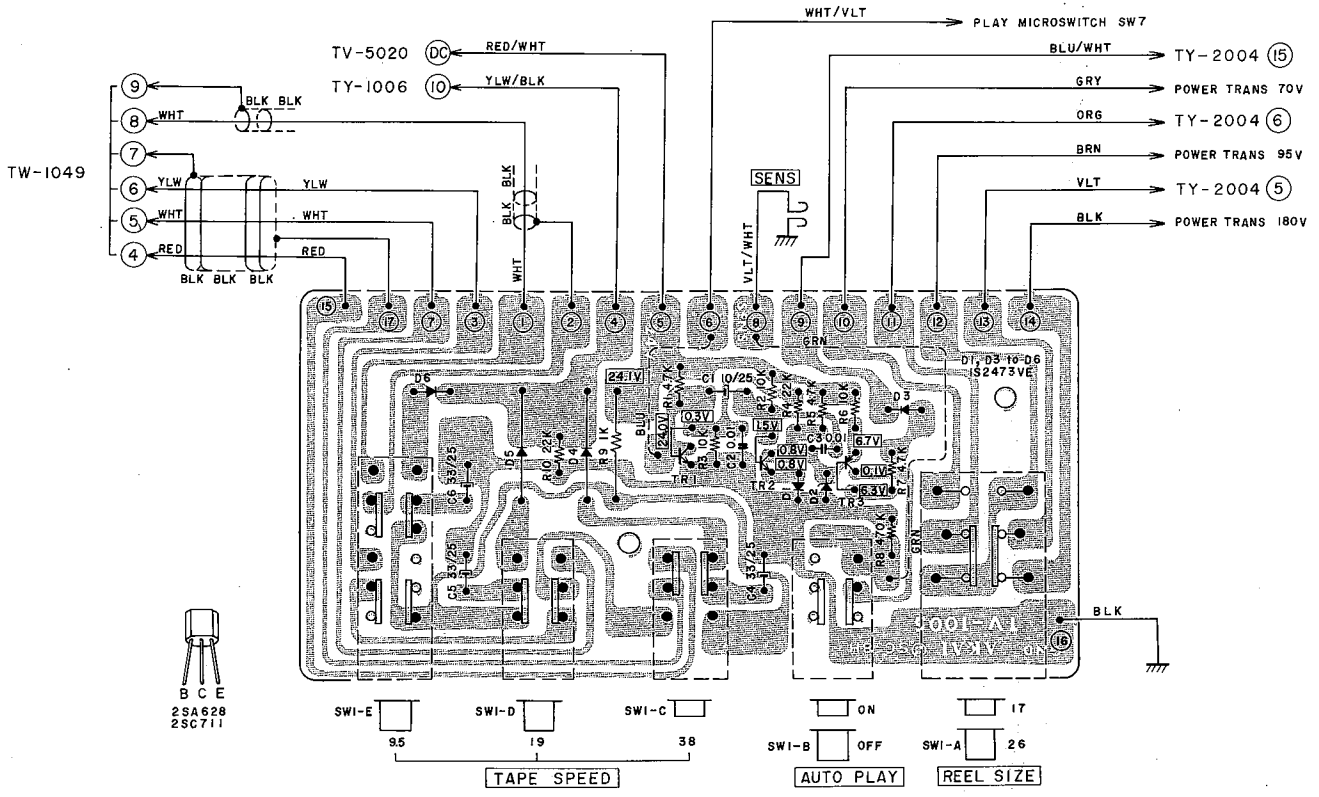



# 7. RELAY P.C BOARD TY-2004

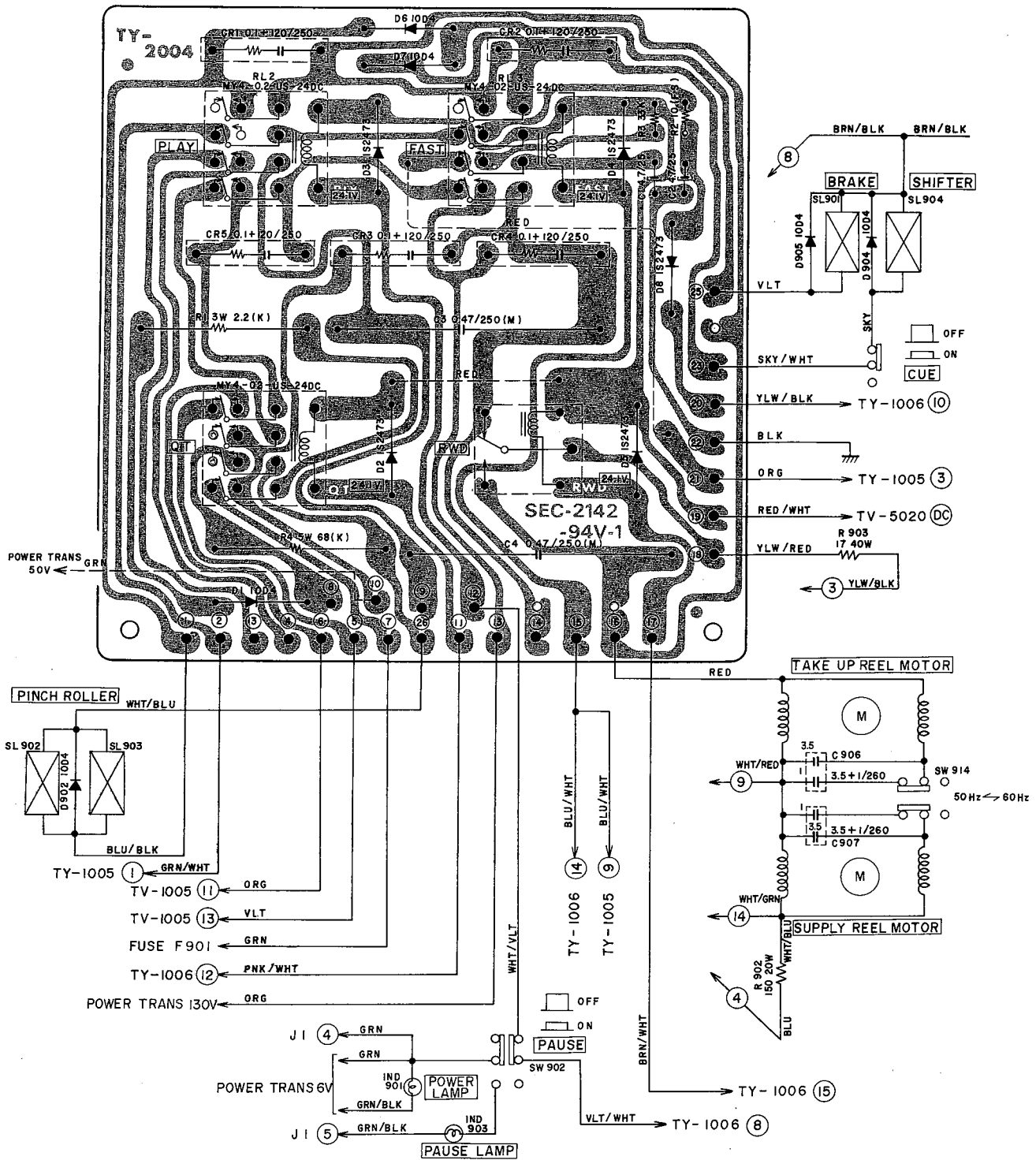

# 8. SERVO P.C BOARD TW-1049

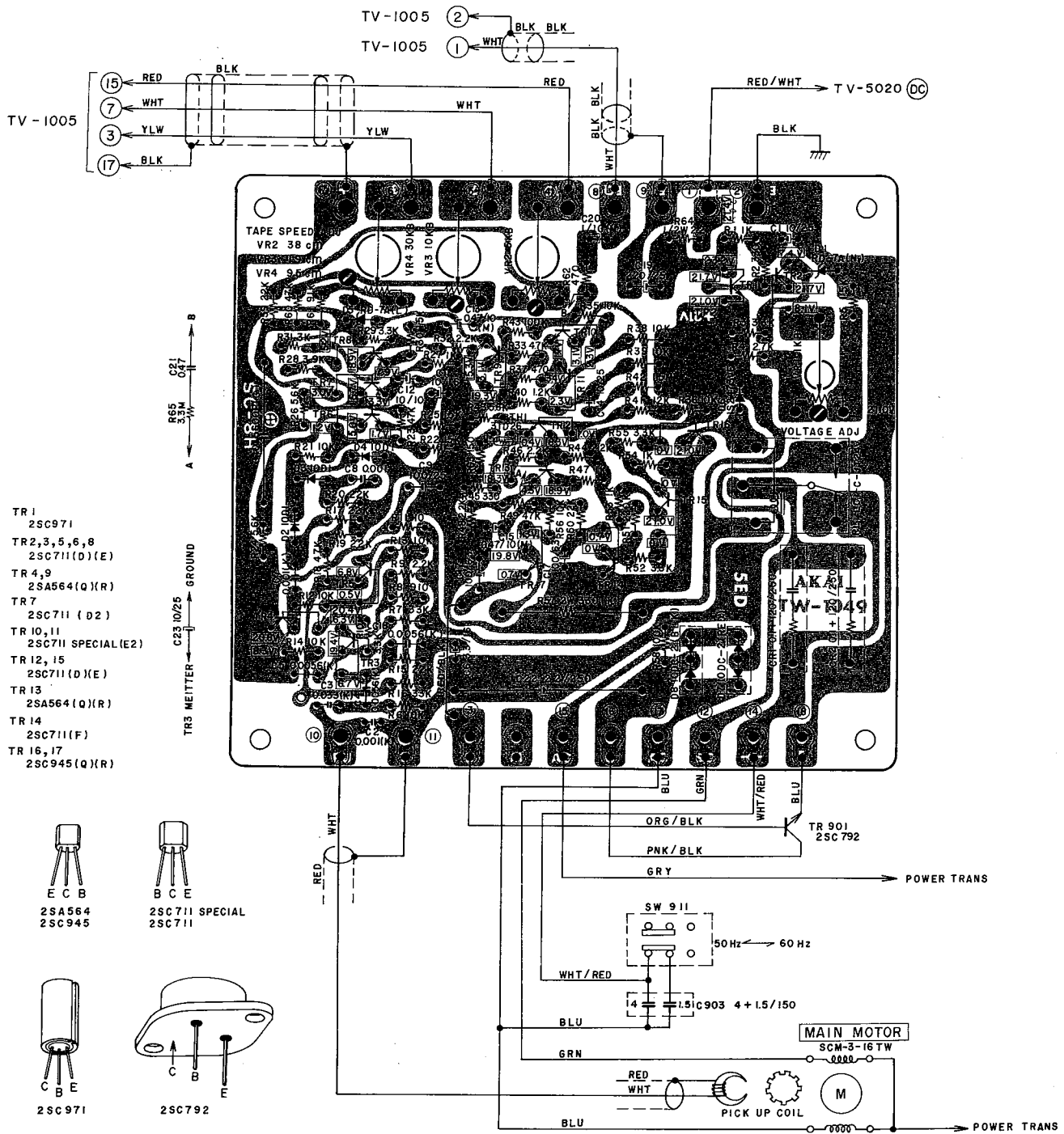

9. HOLE IC P.C BOARD TY-1005

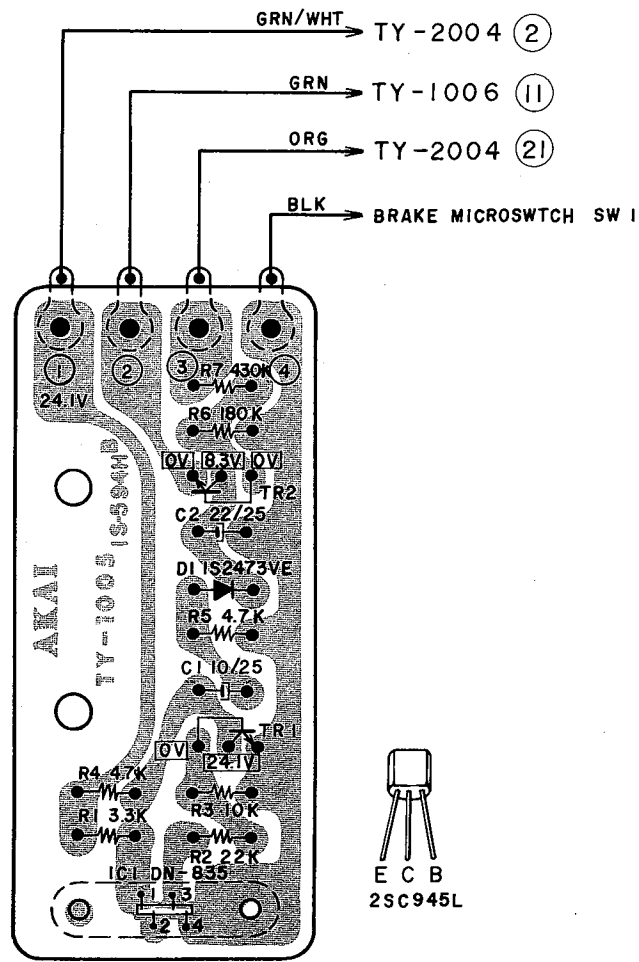

10. SYS. CON P.C BOARD TY-1006

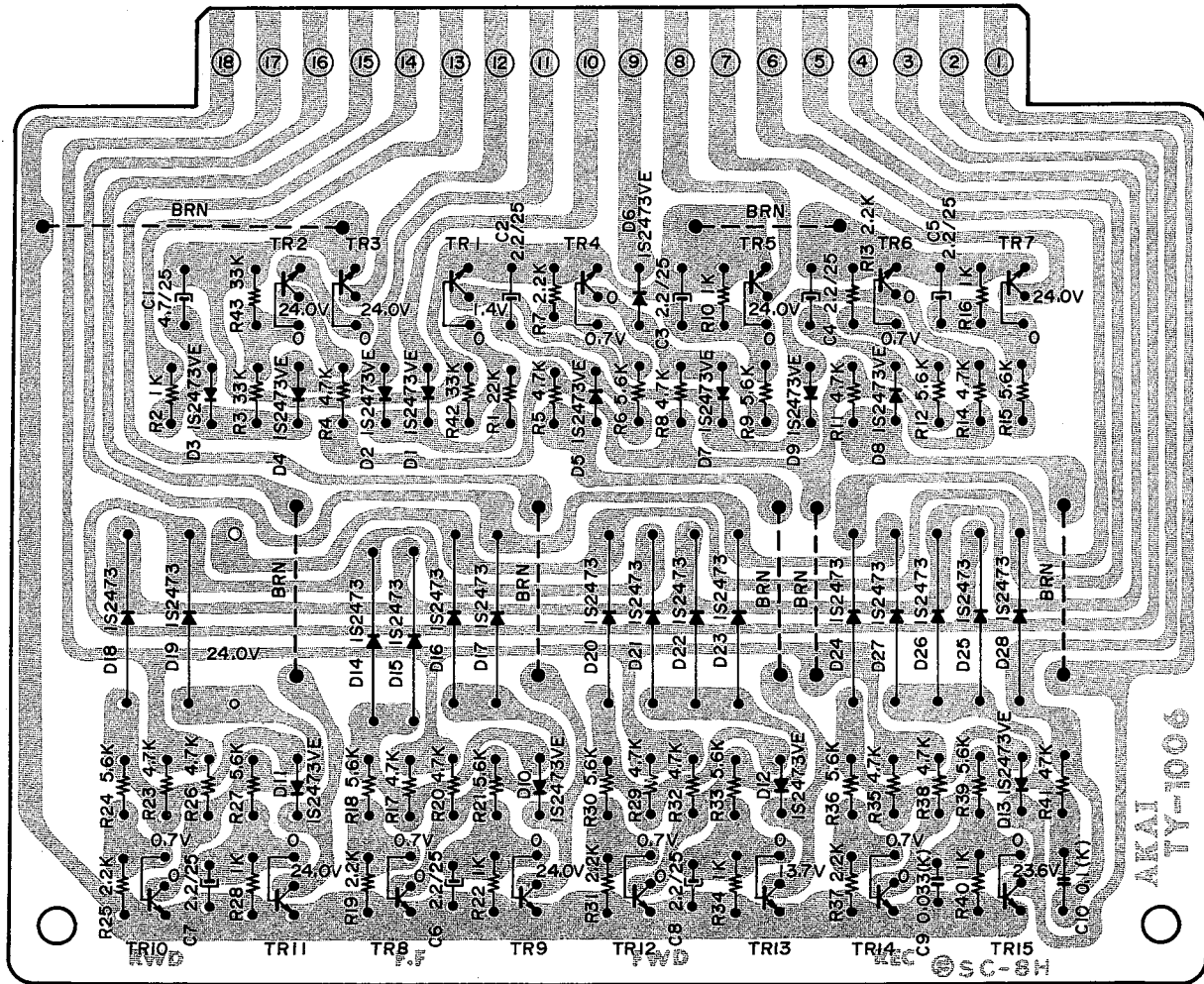

TR 1 to TR 6    2SC945L(P)(Q)    TR 7, TR 15    2SC1247A(B)(V)  
 TR 8 to TR 14

# 11. POWER SUPPLY P.C BOARD TV-5020

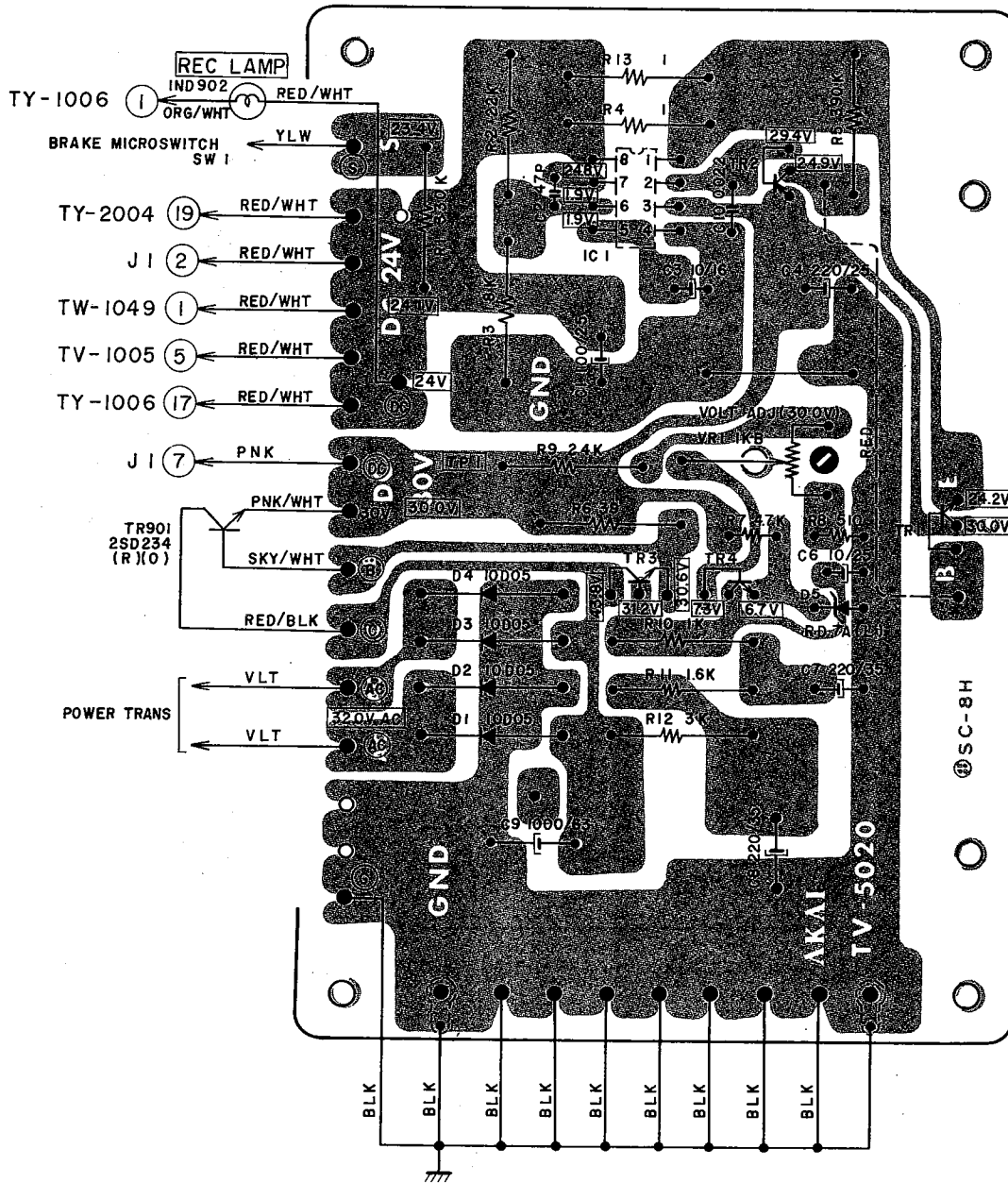

- TR1 2SD361(D)(E)
- TR2 2SA733(P)(Q)
- TR3 2SC1014(C)(D)
- TR4 2SC945L(P)(Q)
- IC 1 JPC 305

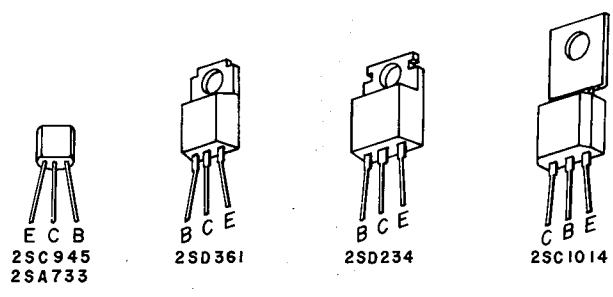

## BASIC PARTS LIST

Parts No.	Description	Schematic No.
SK214143	Push Button A Part	TV-6008
SK237971	Push Button B Part	TV-6008
ZW214121	Tension Arm Washer	TV-6007
SP213704	Sub Panel	TV-6010
SK214233	Amp. Knob C-1	TV-6014
SK214244	Amp. Knob C-2	TV-6014
SK214255	Bias Knob	TV-6015
SK214187	Pre-Set Knob A	TV-6013
SK214211	Pre-Set Knob B	TV-6013
SK214154	Amp. Knob A-1	TV-6011
SK214165	Amp. Knob A-2	TV-6011
SK214176	Amp. Knob B	TV-6012
BC213478	Mecha. Case	TV-6017
EZ213557	Connector Cover	TV-6019
SE214266	Case Bush	TV-6018
SA214277	Square Foot A (Part)	TV-6020
SA214288	Square Foot B (Part)	TV-6020
BC234292	Amp. Case	TV-6022
SP228947	Mecha. Panel	TV-6001
SC214391	Head Cover Base	TV-6004
SZ214413	Head Cover Holder	TV-6005
SC213502	Head Cover	TV-6006
SE214110	Tension Arm Escutcheon	TV-6003
SP213682	Amp. Panel	TV-6009
EJ214378	Jack Plate	TV-5011
MZ216180	Main Case Cap	TV-1001
SB227788	Operate Button A	TV-2006
SB227790	Operate Button B	TV-2006
SB219633	Operate Button C	TV-2006
SB219644	Operate Button D	TV-2006
SB219677	Operate Button E	TV-2006
SB219767	Operate Button F	TV-2006
BA293782	Sys. Con P.C Board	TY-1008
EI213827	IC MPC-305C	
ES228960	Tape Switch (1)-A	CI-6028
ES216134	Tape Switch (2)-A	CI-6029
EJ246565	Jack Plate TV	31-5-135
ES213805	Slide Switch TV	
BA236417	Equalizer Sw. P.C Board Comp.	TV-5021
BA236430	Monitor Sw. P.C Board Comp.	TV-5022
BA236452	Selector Sw. P.C Board Comp.	TV-5024

Parts No.	Description	Schematic No.
BA236474	Trimmer Vol. P.C Board Comp.	TV-5026
EJ619187	Plug 11P (W/Flange) PA-6038-00	42-1-81
EJ619198	Socket US S8-4038-00	
BL236373	Tension Arm (R) Block Comp.	
BL236362	Tension Arm (L) Block Comp.	
EM213761	VU Meter TV	
BZ236327	Operation Block Comp.	
BA293826	Servo P.C Board Comp. TV	
BH236294	Head Block.	
EW246532	Output Cord A TV	
EW262697	AC Cord B	
EW246554	Output Cord C TV	
BA662837	Relay P.C Board Comp.	TY-2018
ES213840	Lever Switch SLK04202	
BA236441	Volume P.C Board Comp.	TV-5023
BA236463	OSC P.C Board Comp.	TV-5025
ES213412	Rotary Switch SRD-L1043	
EV213366	Vol. DJ10E 50KBx2	
EV269976	Single Axial 2 Throw Vol.	
EV213355	Double Vol. DJ60E 50KBx2	
ES213895	Lever Switch SLK04301	
EV213941	Single Axial 2 Throw Vol.	
EV213928	Single Axial 2 Throw Vol.	
SK691288	Selector Knob	CI-6020

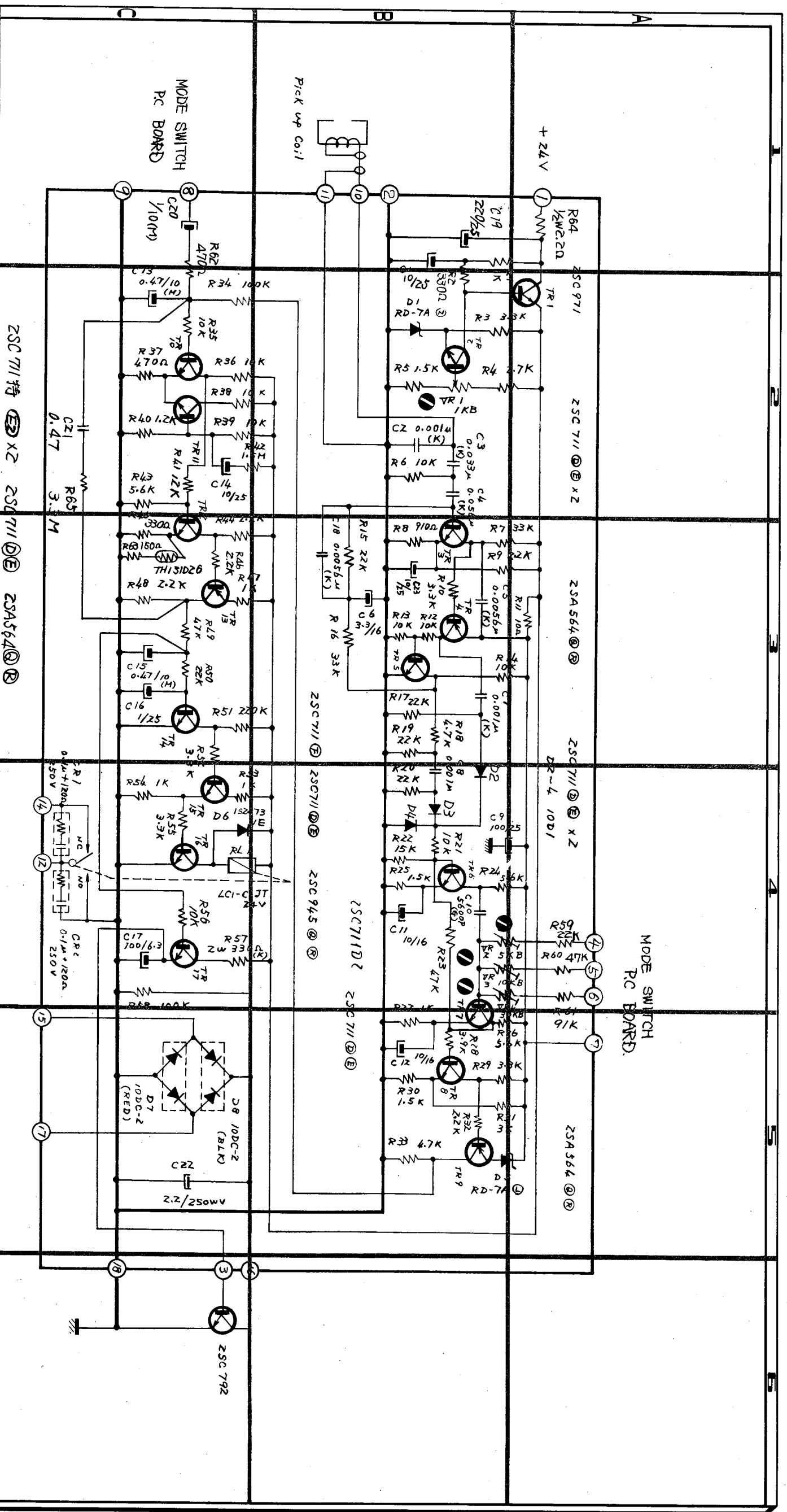

NOTE  
 UNLESS OTHERWISE SPECIFIED  
 ALL RESISTORS IN OHMS 1/4W(J)  
 ALL CAPACITORS IN μF 50WV(J)

TW Schematic Diagram  
 (Sero Block)  
 No. 000414

(Last No)  
 C ---- 22  
 R ---- 45



**PRO 1000**  
SCHEMATIC DIAGRAM  
MECHA BLOCK  
NO. 000903

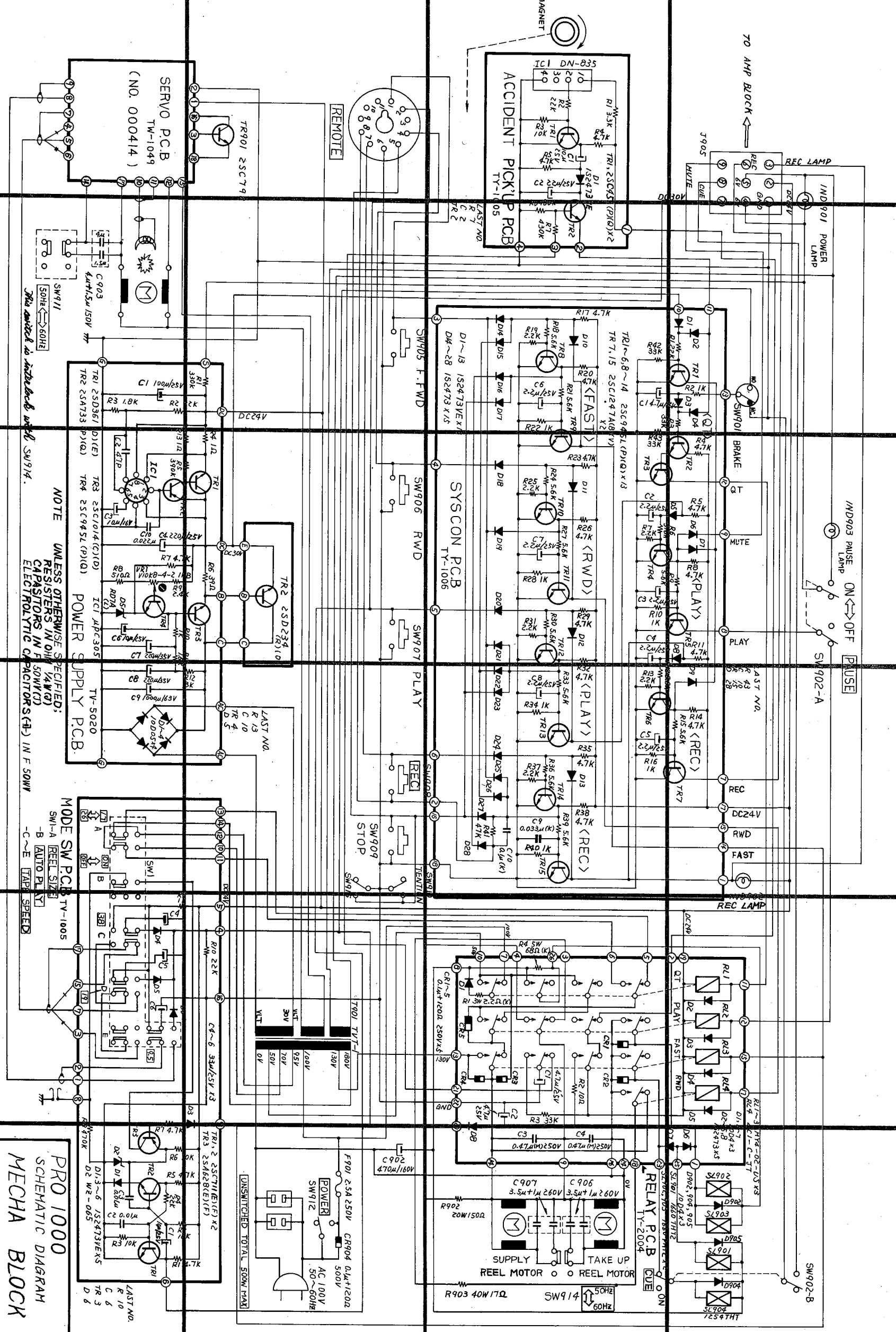

NOTE  
UNLESS OTHERWISE SPECIFIED:  
RESISTORS IN OHM (W) (V)  
CAPACITORS IN P (N) (M) (U)  
ELECTROLYTIC CAPACITORS (E) IN F (S) (M)

POWER SUPPLY PCB  
TV-5020

MODE SW PCB  
TV-1005

LAST NO.  
R 10  
C 6  
TR 3  
D 6

UNSWITCHED TOTAL 500W MAX

F901 2.5A 250V CR904 0.1K+1202  
500V  
AC 100V  
SW912  
50~60HZ

SUPPLY TAKE UP  
REEL MOTOR REEL MOTOR

RELAY PCB  
TY-2004

SW914  
50HZ  
60HZ

R903 40W 17Q

C902 470u/160V

C907 3.5u+1m 260V

C906 3.5u+1m 260V

R902 20W 150Q

R901 40W 17Q

R900 20W 150Q

R903 40W 17Q

R902 20W 150Q

R901 40W 17Q

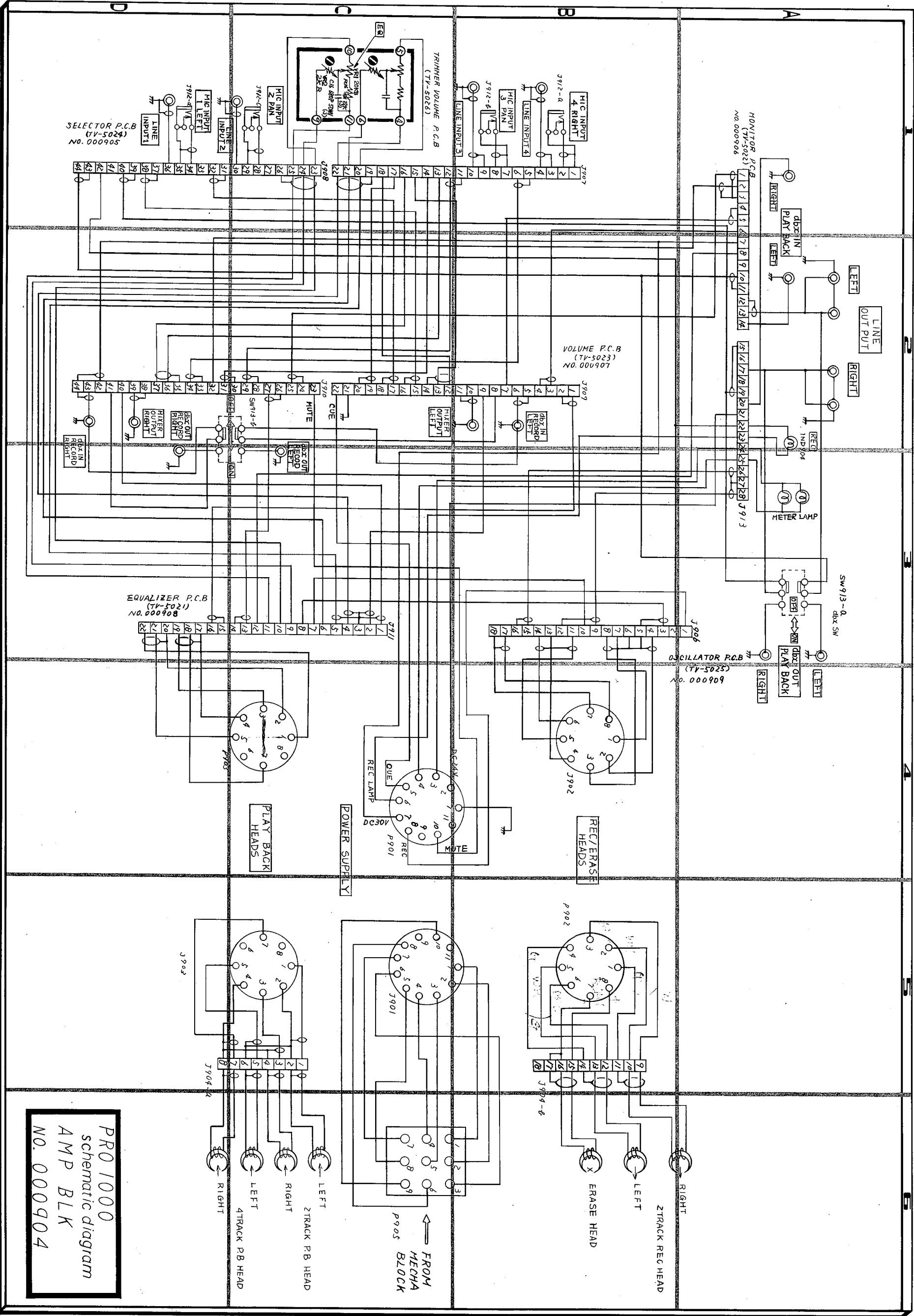

PR0 1000  
 schematic diagram  
 AMP BLK  
 NO. 000904

FROM  
 MECHA  
 P905

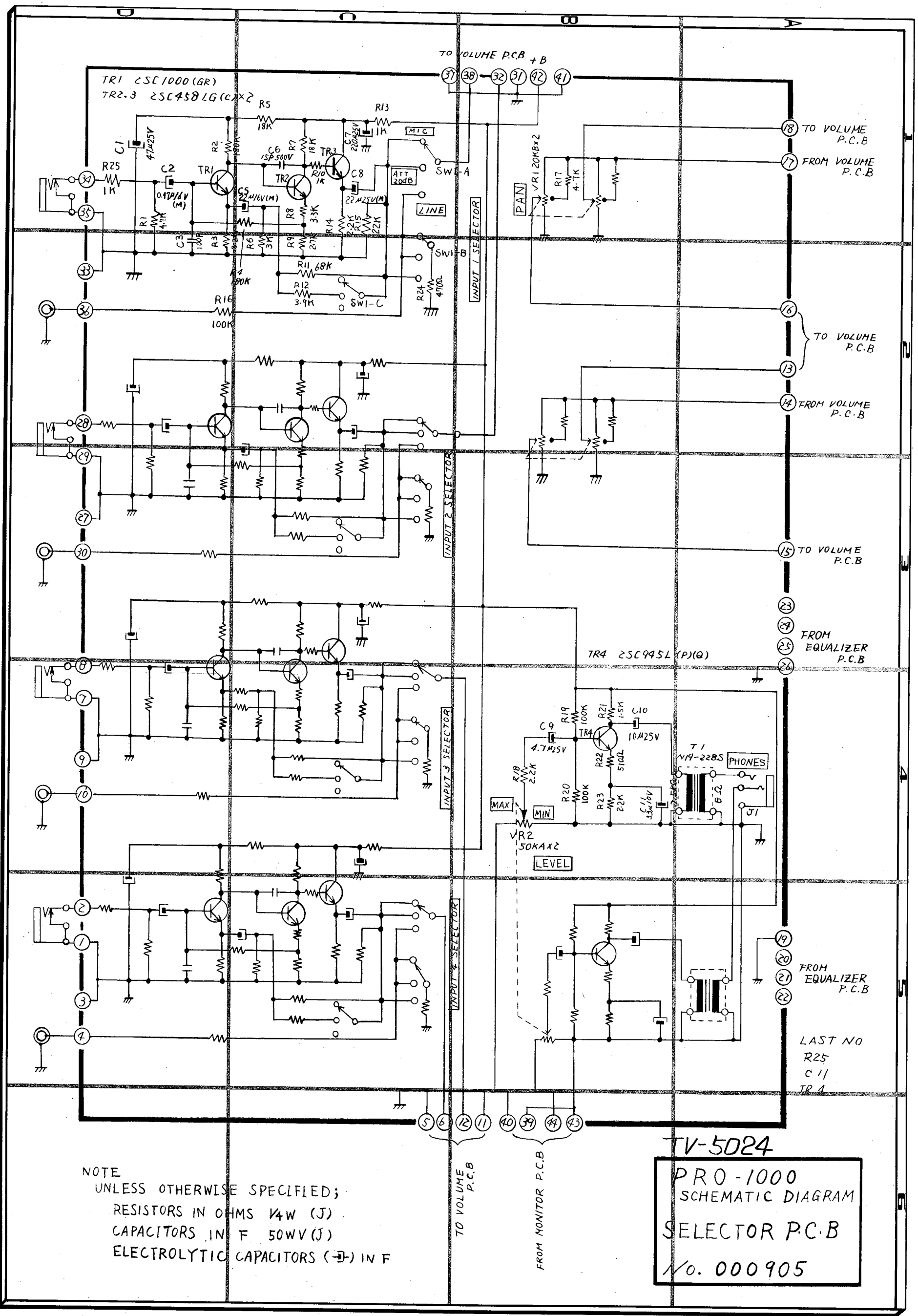

NOTE  
 UNLESS OTHERWISE SPECIFIED;  
 RESISTORS IN OHMS 1/4W (J)  
 CAPACITORS IN F 50WV (J)  
 ELECTROLYTIC CAPACITORS (E) IN F

TV-5024  
 PRO-1000  
 SCHEMATIC DIAGRAM  
 SELECTOR P.C.B  
 No. 000905

LAST NO  
 R25  
 C11  
 TR4

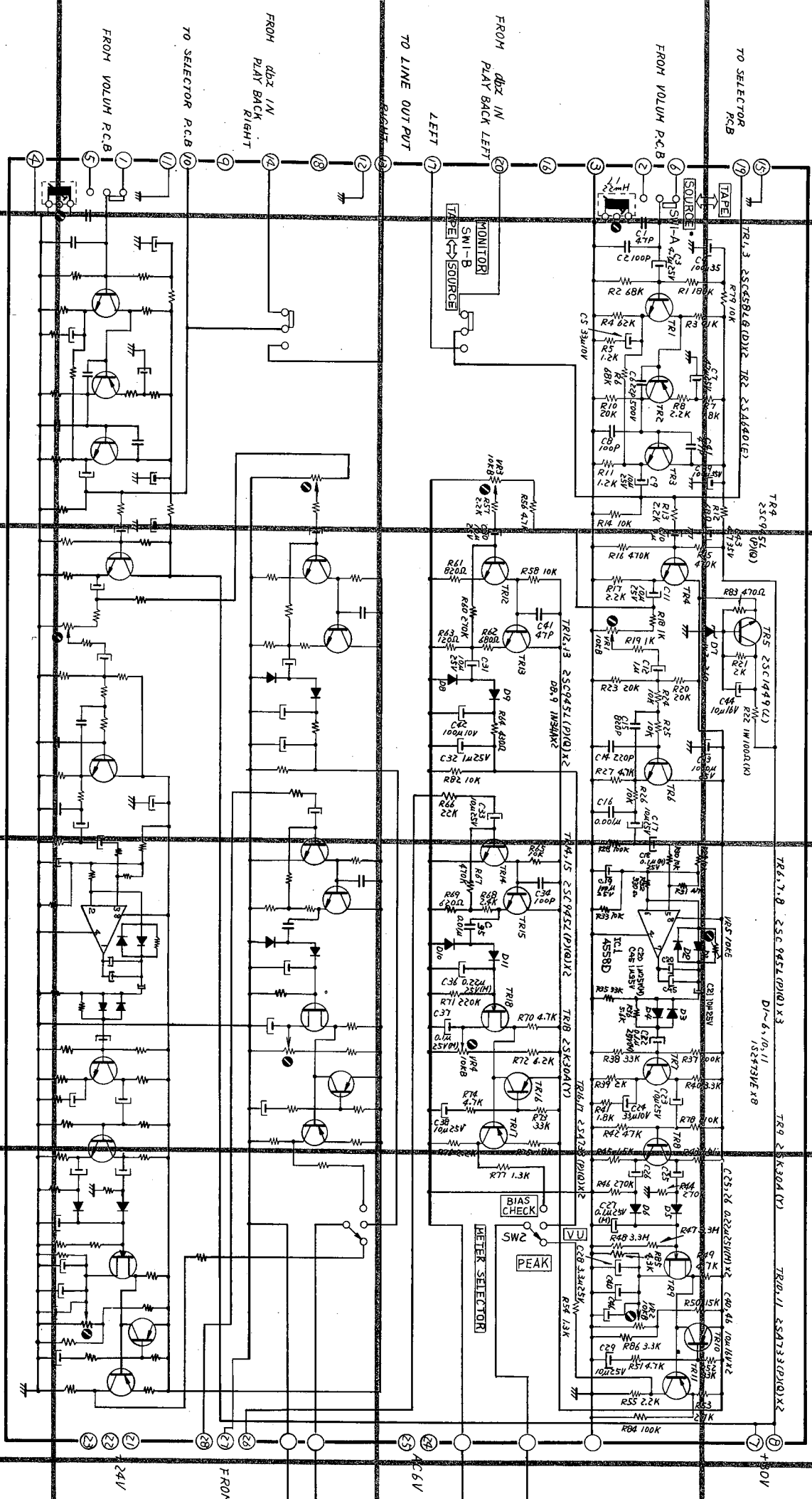

NOTE  
UNLESS OTHERWISE SPECIFIED:  
RESISTORS IN OHMS 1/4W  
CAPACITORS IN F 50WV (J)  
ELECTROLYTIC CAPACITORS (E) IN F 50WV

LAST NO. TV-5022  
R 86  
C 46  
TR 18  
D 11

PRO 1000  
SCHEMATIC DIAGRAM  
MONITOR P.C.B.  
NO. 000906

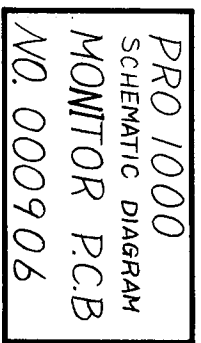

FROM OSCILLATOR P.C.B.

PRO 1000  
SCHEMATIC DIAGRAM  
VOLUME P.C.B  
NO 000907

TV-5023

LAST NO.  
R 63  
C 30  
TR 13

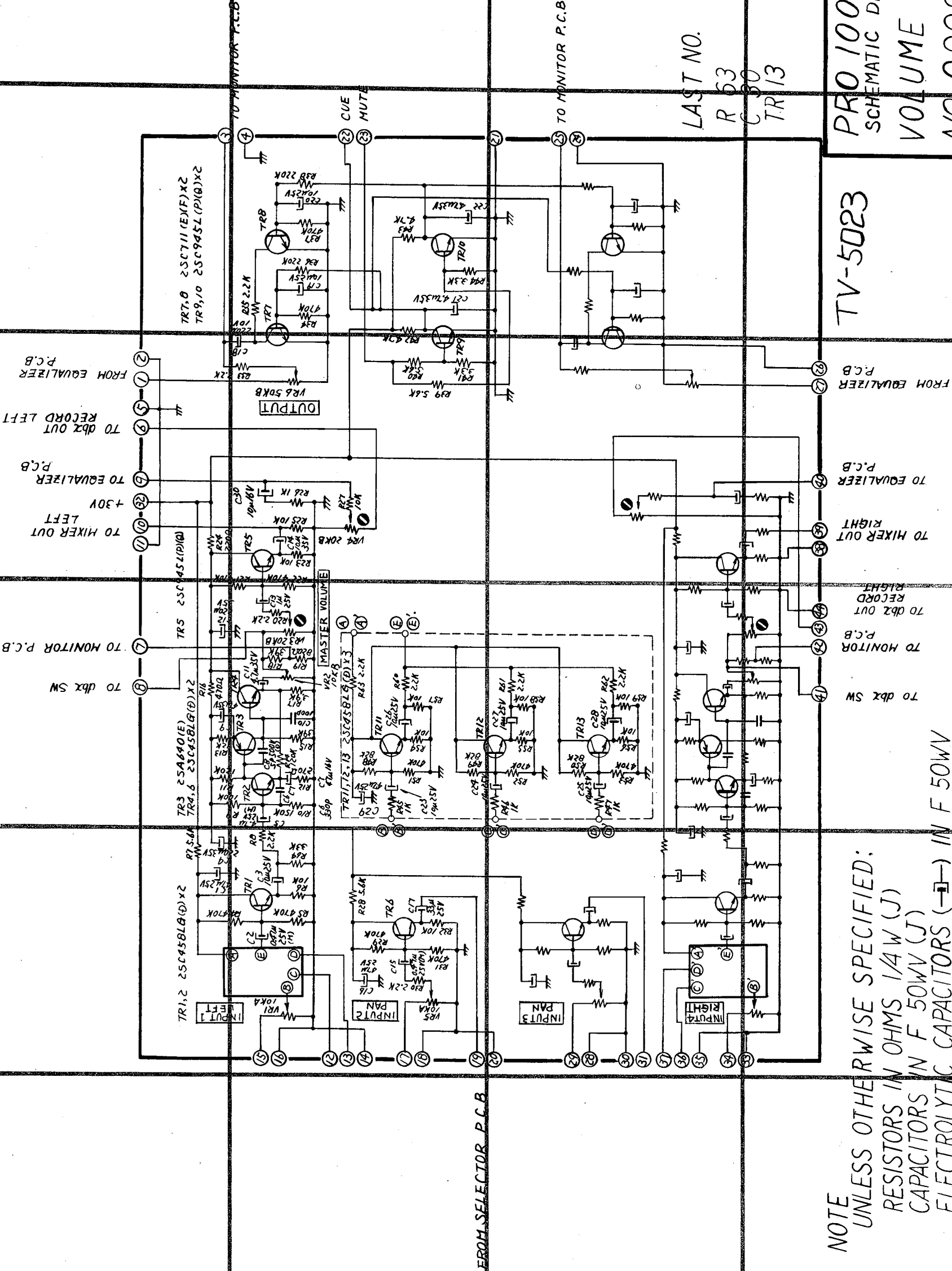

NOTE  
UNLESS OTHERWISE SPECIFIED:  
RESISTORS IN OHMS 1/4 W (J)  
CAPACITORS IN F 50WV (J)  
ELECTROLYTIC CAPACITORS (—) IN F 50WV

NOTE  
UNLESS OTHERWISE  
SPECIFIED:  
RESISTORS IN  
OHMS 1/4W (J)  
CAPASITORS IN  
F 50MV (J)  
ELECTROLYTIC  
CAPASITORS (-) IN F  
\* MARK INDICATE  
LOW LEAKAGE CAPASITOR

# TV-5021

PRO 1000  
SCHEMATIC DIAGRAM  
EQUALIZER PCB

LAST NO  
R 5B  
C 3B  
TR 7  
D 4

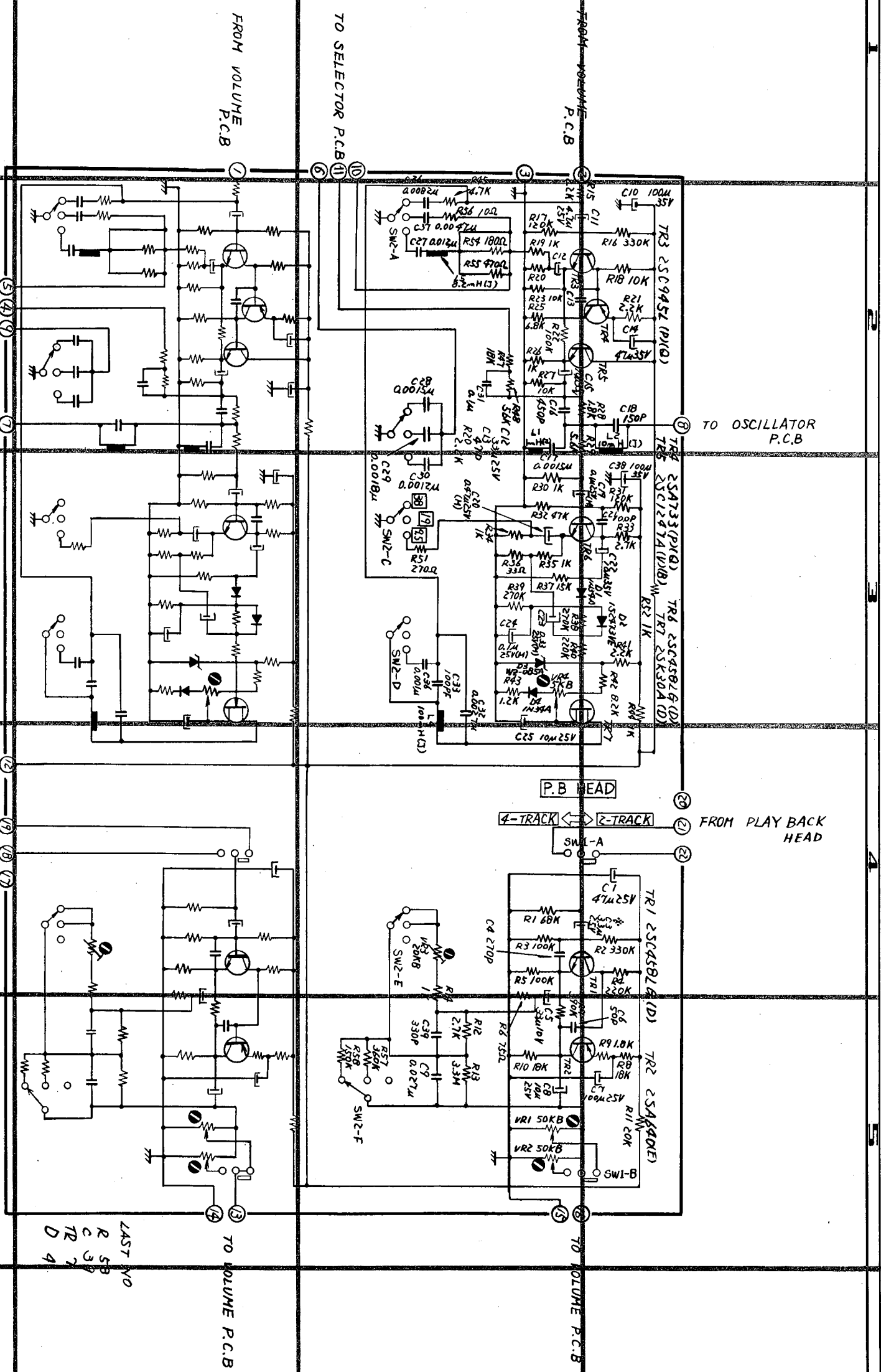

TO SELECTOR P.C.B.  
TO OSSILLATOR P.C.B.

P.B. HEAD

4-TRACK 2-TRACK

FROM PLAY BACK HEAD

TO VOLUME P.C.B.

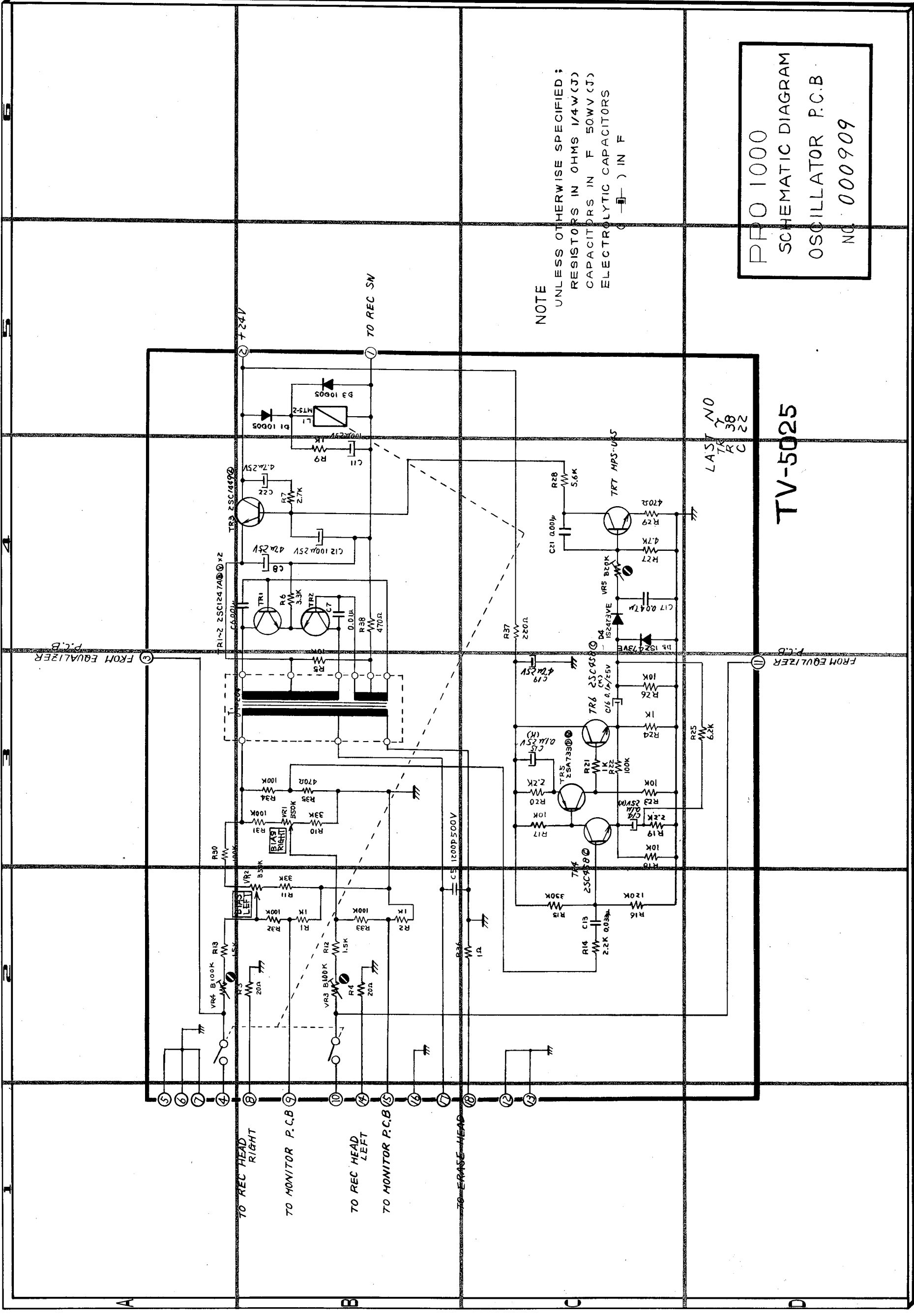

NOTE  
 UNLESS OTHERWISE SPECIFIED;  
 RESISTORS IN OHMS 1/4W(J)  
 CAPACITORS IN F 50WV(J)  
 ELECTROLYTIC CAPACITORS  
 ( ) IN F

PRO 1000  
 SCHEMATIC DIAGRAM  
 OSCILLATOR P.C.B.  
 NO. 000909

TV-5025

LAST NO  
 Y 38  
 R C 22

FROM EQUALIZER P.C.B.

FROM EQUALIZER P.C.B.

TO REC HEAD RIGHT

TO MONITOR P.C.B.

TO REC HEAD LEFT

TO MONITOR P.C.B.

TO ERASE HEAD

A

B

C

D

1

2

3

4

5

6